

User Manual

NCP-1701 Console Terminal LCD Keyboard Drawer



- 1U 17" screen size
- Designed for SUN, all headless servers

Contents

Chapter 1 **Getting Started**

1.1	Important Safeguards.....	1
1.2	Regulatory Notice.....	2
1.3	Package Contents.....	3
1.4	Before Installation.....	4
1.5	Unpacking.....	4
1.6	Optional Accessories.....	4
1.7	Peripheral Products.....	5
1.8	Structure Diagram.....	5
1.9	Installation.....	6
1.10	How to Use "NCP" Series LCD Keyboard Drawer.....	7
1.11	How to Use the Slides	8
1.12	How to Use "One Man" Installation Slides	9-11
1.13	Connect to Single Serial Device or Headless Server.....	12
1.14	Connect to Multi-port IP Serial Console.....	13
1.15	Device Setup.....	14
1.16	Changing Operating Parameters.....	15-22
1.17	Local Keyboard Commands in Native Mode.....	23
1.18	Connector Pin Assignment.....	24
1.19	Command Guide.....	24-31
1.20	Variable Values for Commands.....	32-36
1.21	Using the Printer Server in Ethernet Terminal.....	37-39

Chapter 2 **Operation**

2.1	On-screen Display Operation.....	40
2.2	On-screen Menu.....	41

Chapter 3 **Standard Specification**

3.1	Specifications.....	42
3.2	Keyboard.....	43

Chapter 4 **Optional Specification**

4.1	DC Power Options.....	43
-----	-----------------------	----

Chapter 5 **FAQ**.....44-45

Chapter 6 **Dimensions**.....46

1.1 Important Safeguards

Chapter 1

Please read all of these instructions carefully before you use the device. Save this manual for future reference.

What the warranty does not cover

- Any product, on which the serial number has been defaced, modified or removed.
- Damage, deterioration or malfunction resulting from:
 - Accident, misuse, neglect, fire, water, lightning, or other acts of nature, unauthorized product modification, or failure to follow instructions supplied with the product.
 - Repair or attempted repair by anyone not authorized by us.
 - Any damage of the product due to shipment.
 - Removal or installation of the product.
 - Causes external to the product, such as electric power fluctuation or failure.
 - Use of supplies or parts not meeting our specifications.
 - Normal wear and tear.
 - Any other causes which does not relate to a product defect.
- Removal, installation, and set-up service charges.

Legal Information

First English printing, October 2002

Information in this document has been carefully checked for accuracy; however, no guarantee is given to the correctness of the contents. The information in this document is subject to change without notice. We are not liable for any injury or loss that results from the use of this equipment.

Safety Instructions

- Unplug equipment before cleaning. Don't use liquid or spray detergent; use a moist cloth.
- Keep equipment away from excessive humidity and heat. Preferably, keep it in an air-conditioned environment with temperatures not exceeding 40° Celsius (104° Fahrenheit).
- When installing, place the equipment on a sturdy, level surface to prevent it from accidentally falling and causing damage to other equipment or injury to persons nearby.
- When the drawer is in an open position, do not cover, block or in any way obstruct the gap between it and the power supply. Proper air convection is necessary to keep it from overheating.
- Arrange the equipment's power cord in such a way that others won't trip or fall over it.
- If you are using a power cord that didn't ship with the equipment, ensure that it is rated for the voltage and current labeled on the equipment's electrical ratings label. The voltage rating on the cord should be higher than the one listed on the equipment's ratings label.
- Observe all precautions and warnings attached to the equipment.
- If you don't intend on using the equipment for a long time, disconnect it from the power outlet to prevent being damaged by transient over-voltage.
- Keep all liquids away from the equipment to minimize the risk of accidental spillage. Liquid spilled on to the power supply or on other hardware may cause damage, fire or electrical shock.
- Only qualified service personnel should open the chassis. Opening it yourself could damage the equipment and invalidate its warranty.
- If any part of the equipment becomes damaged or stops functioning, have it checked by qualified service personnel.

Regulatory Notices Federal Communications Commission (FCC)

This equipment has been tested and found to comply with the limits for a Class B digital device, pursuant to Part 15 of the FCC rules. These limits are designed to provide reasonable protection against harmful interference in a residential installation.

Any changes or modifications made to this equipment may void the user's authority to operate this equipment. This equipment generates, uses, and can radiate radio frequency energy and, if not installed and used in accordance with the instructions, may cause harmful interference to radio communications.

However, there is no guarantee that interference will not occur in a particular installation. If this equipment does cause harmful interference to radio or television reception, which can be determined by turning the equipment off and on, the user is encouraged to try to correct the interference by one or more of the following measures:

- Re-position or relocate the receiving antenna.
- Increase the separation between the equipment and receiver.
- Connect the equipment into an outlet on a circuit different from that to which the receiver is connected.

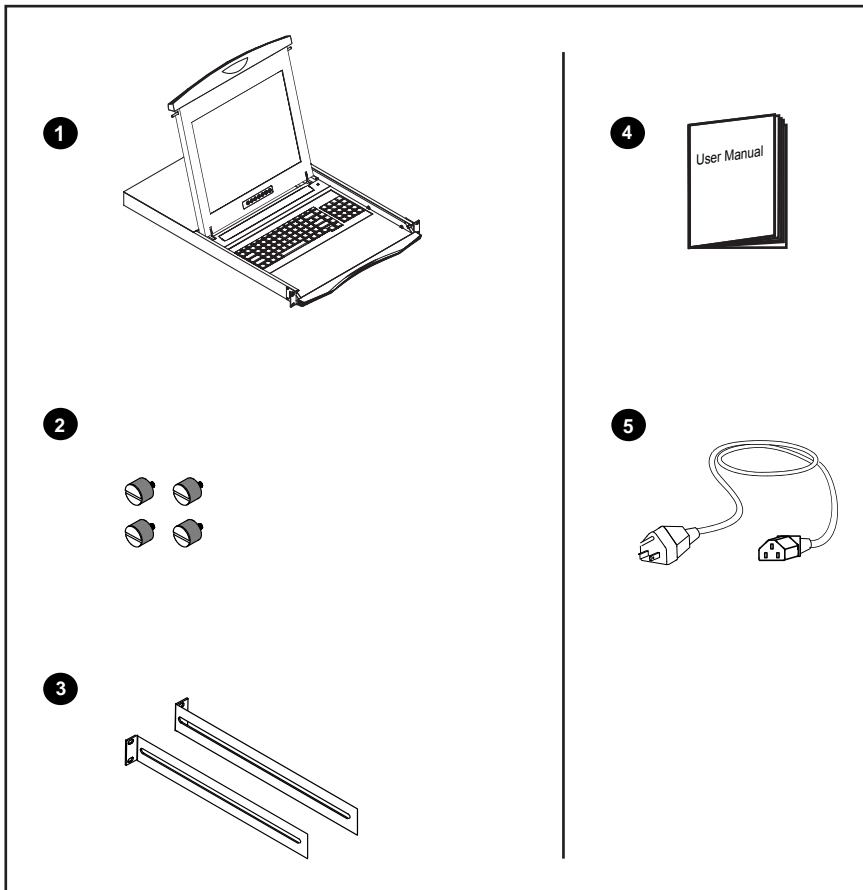

- ① Console terminal LCD keyboard drawer x 1 pc
- ② Fasteners for rear L-bracket x 4 pcs
- ③ 330mm rear mounting L-bracket x 1 pair
* NCP-1701 mounting depth-adjustable from 315 to 880mm
- ④ User manual x 1 pc
- ⑤ Power cord x 1 pc

1.4 Before Installation

- It is very important to locate the console terminal LCD keyboard drawer in a suitable environment.
- The surface for placing and fixing the Console Terminal Drawer should be stable and level or mounted into a suitable cabinet.
- Make sure the place has good ventilation, is out of direct sunlight, away from sources of excessive dust, dirt, heat, water, moisture and vibration.
- Position the console terminal LCD keyboard drawer with respect to related facilities.

1.5 Unpacking

The console terminal LCD keyboard drawer comes with the standard parts shown on the package contents. Check and make sure they are included and in good condition. If anything is missing, or damage, contact the supplier immediately.

1.6 Optional Accessories

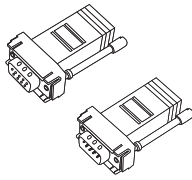
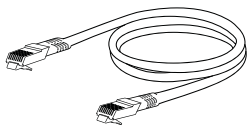
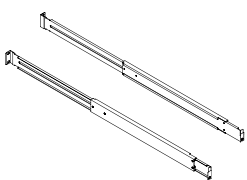
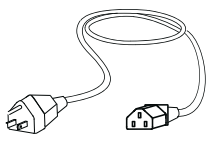
<p>1. RJ45-DB9 adapter</p> <p>1.1 SG-100F RJ45-DB9 female adapter</p> <p>1.2 SG-100M RJ45-DB9 male adapter</p> <p>2. Cat5 Cable</p> <p>2.1 CU-3 3 feet Cat5 cable</p> <p>2.2 CU-6 6 feet Cat5 cable</p> <p>2.3 CU-10 10 feet Cat5 cable</p> <p>2.4 CU-15 15 feet Cat5 cable</p> <p>2.5 CU-33 33 feet Cat5 cable</p> <p>2.6 CU-66 66 feet Cat5 cable</p> <p>3. " One Man" installation slides</p> <p>3.1 NBK-01 Single or "One Man " installation slides</p> <p>* Please refer to P.9 - 11 for Installation guidelines</p> <p>4. Power Cord</p> <p>4.1 IEC power cord</p> <p>4.2 NEMA 5-15 power cord (US)</p> <p>4.3 BS 1363 power cord (UK)</p> <p>4.4 CEE 7/4 power cord (German)</p> <p>4.5 AS 3112 power cord (Australia)</p>	   
---	---

Item	Model No.	Description
Cat5 IP Serial Console	CS-116 / CS-148	16 / 48-port Cat5 IP Serial Console

1.8 Structure Diagram

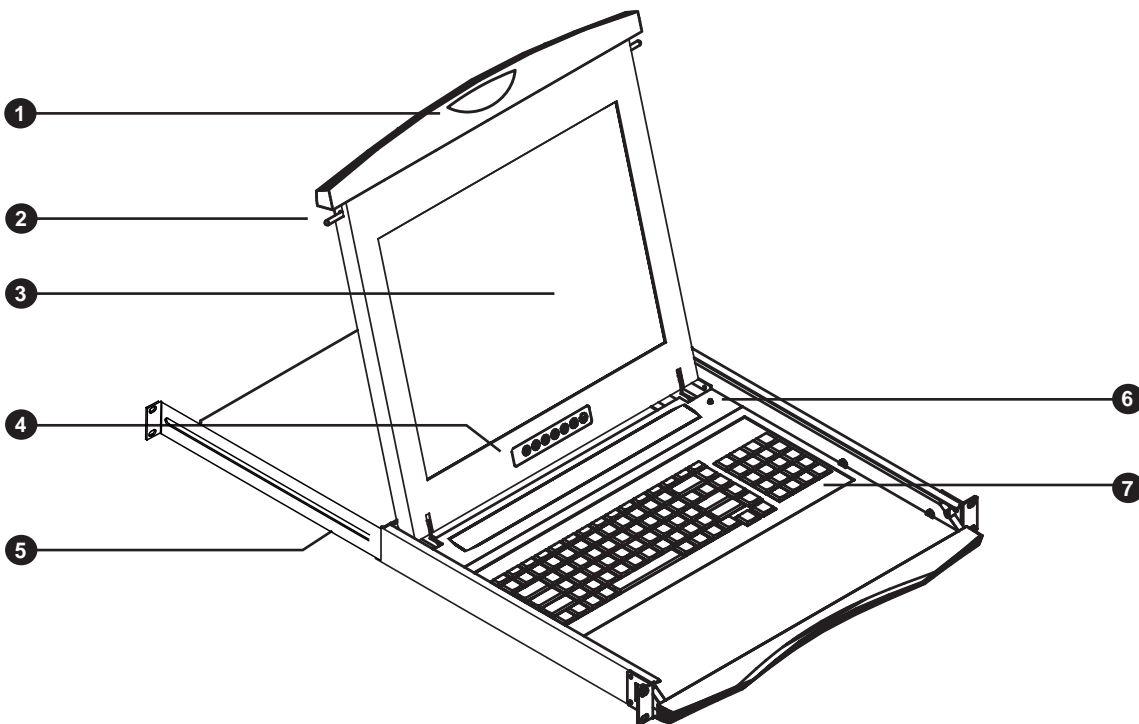

- ① Carry handle to release the 2-pt lock
- ② 2-point lock
- ③ LCD interchangeable module kit
- ④ LCD membrane
- ⑤ Adjustable rear mounting L-bracket
- ⑥ Micro switch for screen auto power off
- ⑦ Keyboard interchangeable module kit

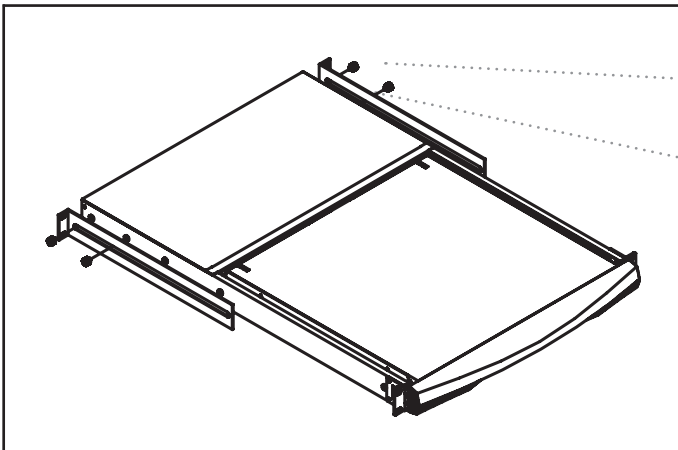
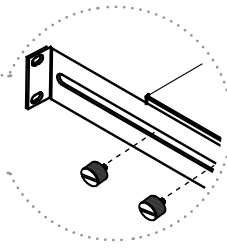

Figure 1. Installing the rear L-bracket to the LCD keyboard drawer.



- Install each rear L-bracket using two fasteners shown in **Figure 1**.
- Leaving the fasteners slightly loose.

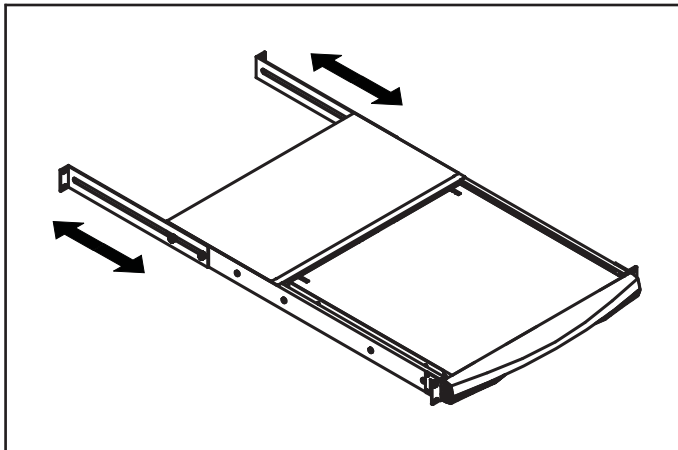

Figure 2. Aligning the rear L-brackets to a suitable length for the rack.

- Measure the front and rear mounting depth of the rack.
- Align each rear L-bracket to a suitable length and tighten the fasteners shown in **Figure 2**.

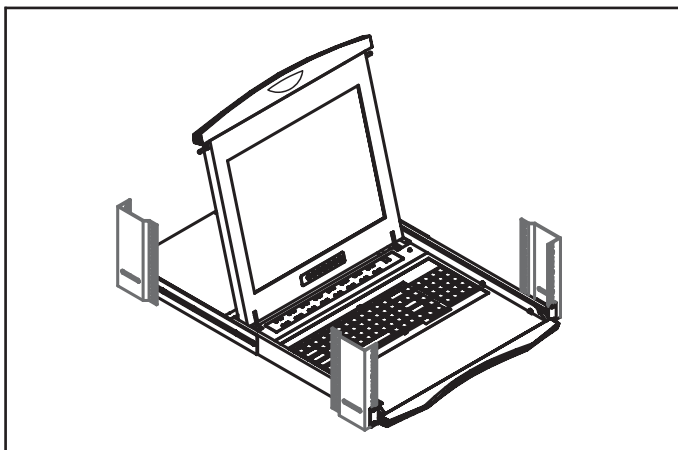

Figure 3. Fixing the LCD keyboard drawer into the rack.

- Fix the LCD keyboard drawer into the rack.
- * Hardware (screws and cage nuts) for fixing the mounting bracket to the rack is not provided.



Figure 4. Pulling the tab toward the front of LCD.

- Gently pull the tab toward the front of the LCD shown in Figure 4.



Figure 5. Flipping up the LCD to a suitable angle.

- Flip up the LCD to a suitable angle shown in Figure 5.



- Operate the LCD keyboard drawer shown in Figure 6.



Figure 7. White arrow button.

- A white arrow release button is located on the outside of each slide (shown in **Figure 7**).



Figure 8. Pushing the white arrow button.

- Push the white arrow button on either side of the LCD keyboard drawer to unlock (shown in **Figure 8**). Avoid pressing the red button located on either side.



Figure 9. Pushing the LCD keyboard drawer into the rack.

- Hold down the white arrow button until the LCD keyboard drawer is located in the rack (shown in **Figure 9**).

Package Contents

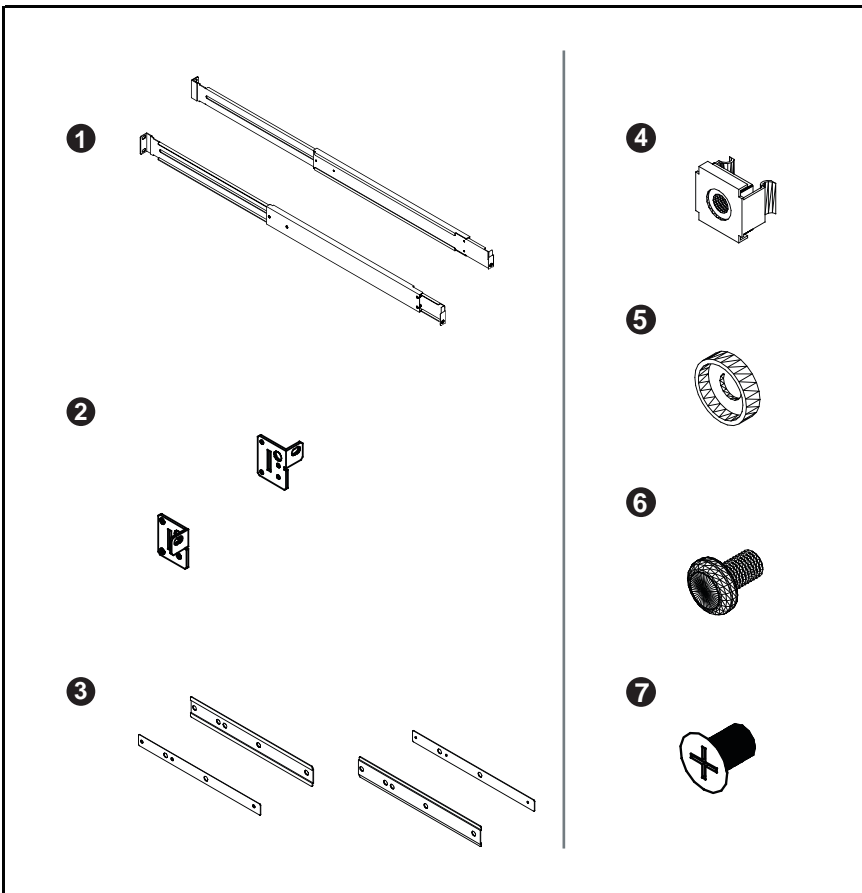

Model No : NBK-01

- ① Mounting bracket x 2 pcs
- ② Front mounting ear (left & right) x 2 pcs
- ③ Support bracket x 4 pcs
- ④ M6 cage nut x 6 pcs
- ⑤ M6 washer x 8 pcs
- ⑥ M6*15mm screw x 8 pcs
- ⑦ M3.2*4.5mm screw x 14 pcs

Install the front mounting ear x 2 pcs

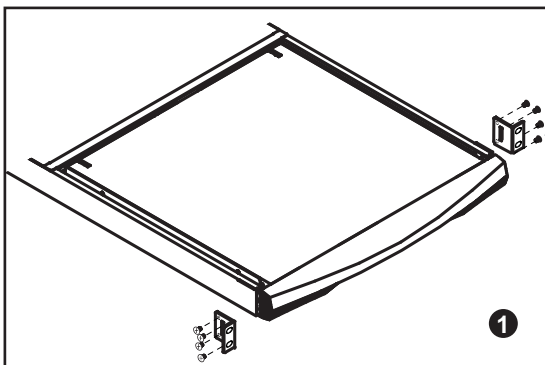

■ Disassemble the standard front mounting ears carefully.

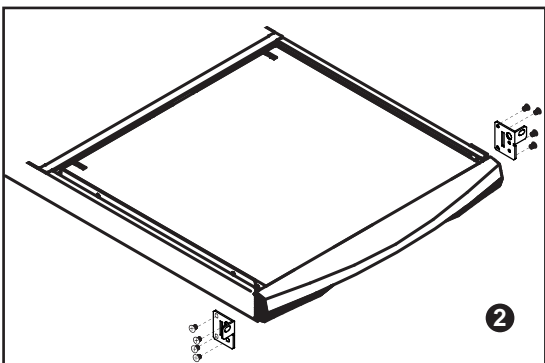

■ Install the optional front mounting ears with M3.2*4.5mm screw x 8 pcs.

Install into rack

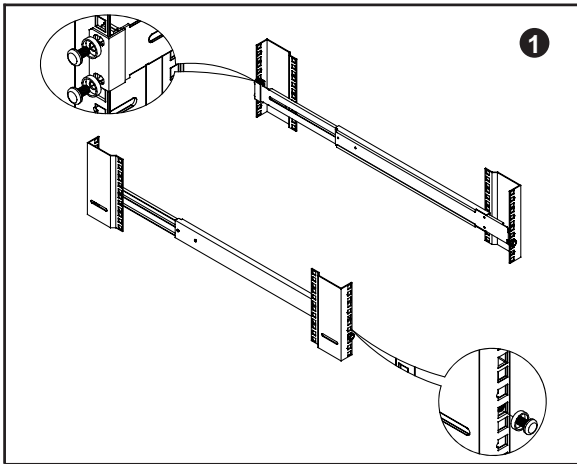

Model No : NBK-01

- Attach the mounting bracket to vertical mounting rails.
- Adjust the rear mounting bracket to fit your rack.
- Repeat the above steps for the other side

⚠ Caution : Leaving the screws slightly loose (Not release).

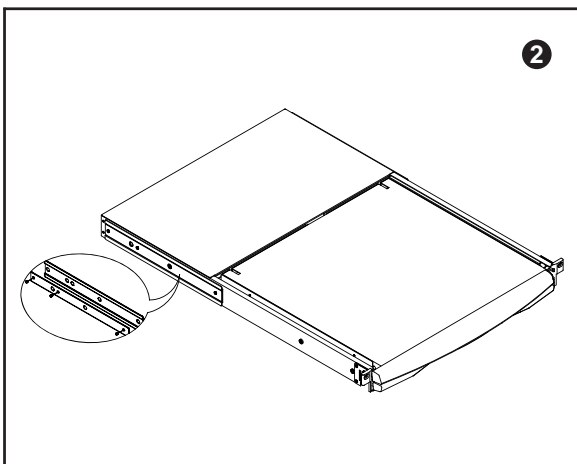

- Attach support brackets to chassis with M3.2*4.5mm screw x 3 pcs.
- Repeat the above step for the other side.

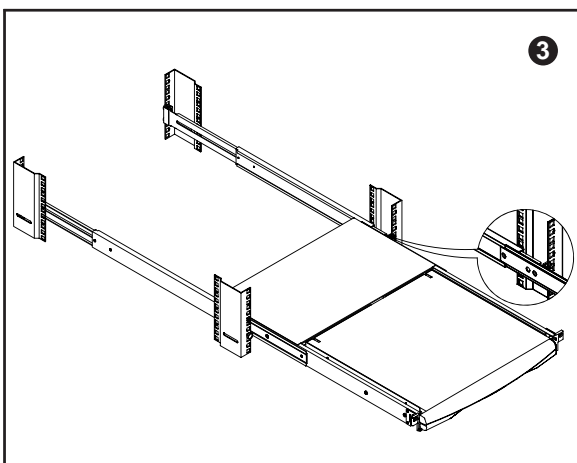

- Pickup the chassis.
- Insert inner members of slides into the already mounted internal slide members in the rack.
- Push the white arrow button on each slide that is installed on the LCD keyboard drawer to unlock (Push at the same time).

⚠ Caution : Be careful when pushing the chassis into the left and right slides. Avoid pressing the red button located on either side of the slide.

Install into rack

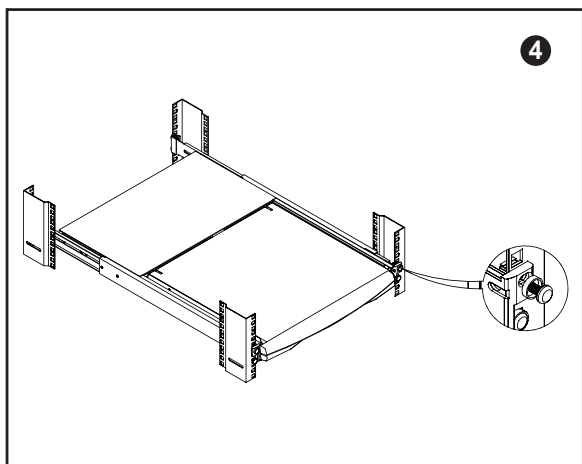

Model No : NBK-01

- Hold down the white arrow button and push the chassis to the end.
- Attach left and right mounting ears to vertical mounting rails.
- Tighten the screws on both sides.

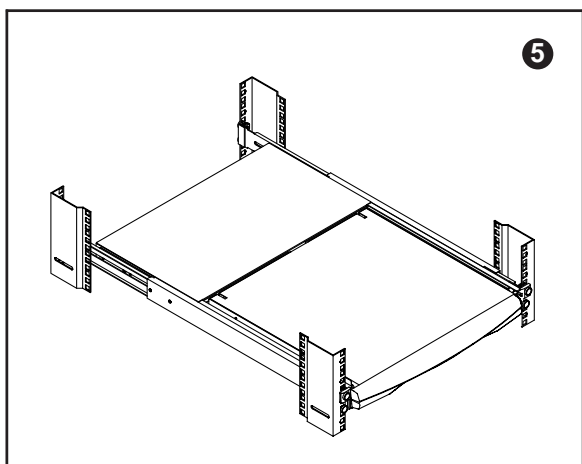

- Installation completed.

Connect to Single Serial Device or Headless Server

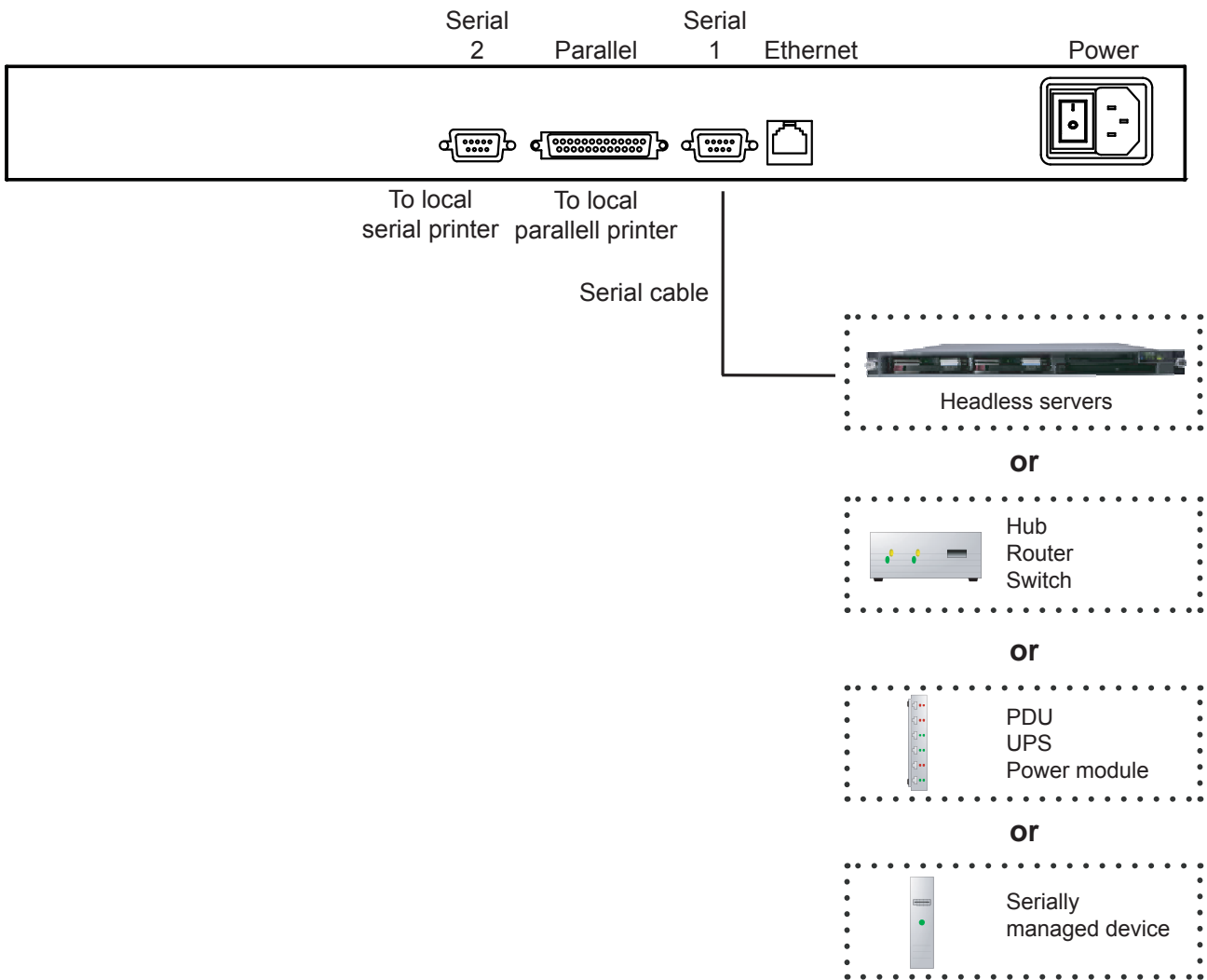

- ① **Power** AC power input
- ② **Ethernet** 10Base-T RJ45 network port
- ③ **Serial 1** DB-9 male RS232 port
- ④ **Parallel** DB-25 male parallel port
- ⑤ **Serial 2** DB-9 male serial printer port

Connect to Multi-port IP Serial Console

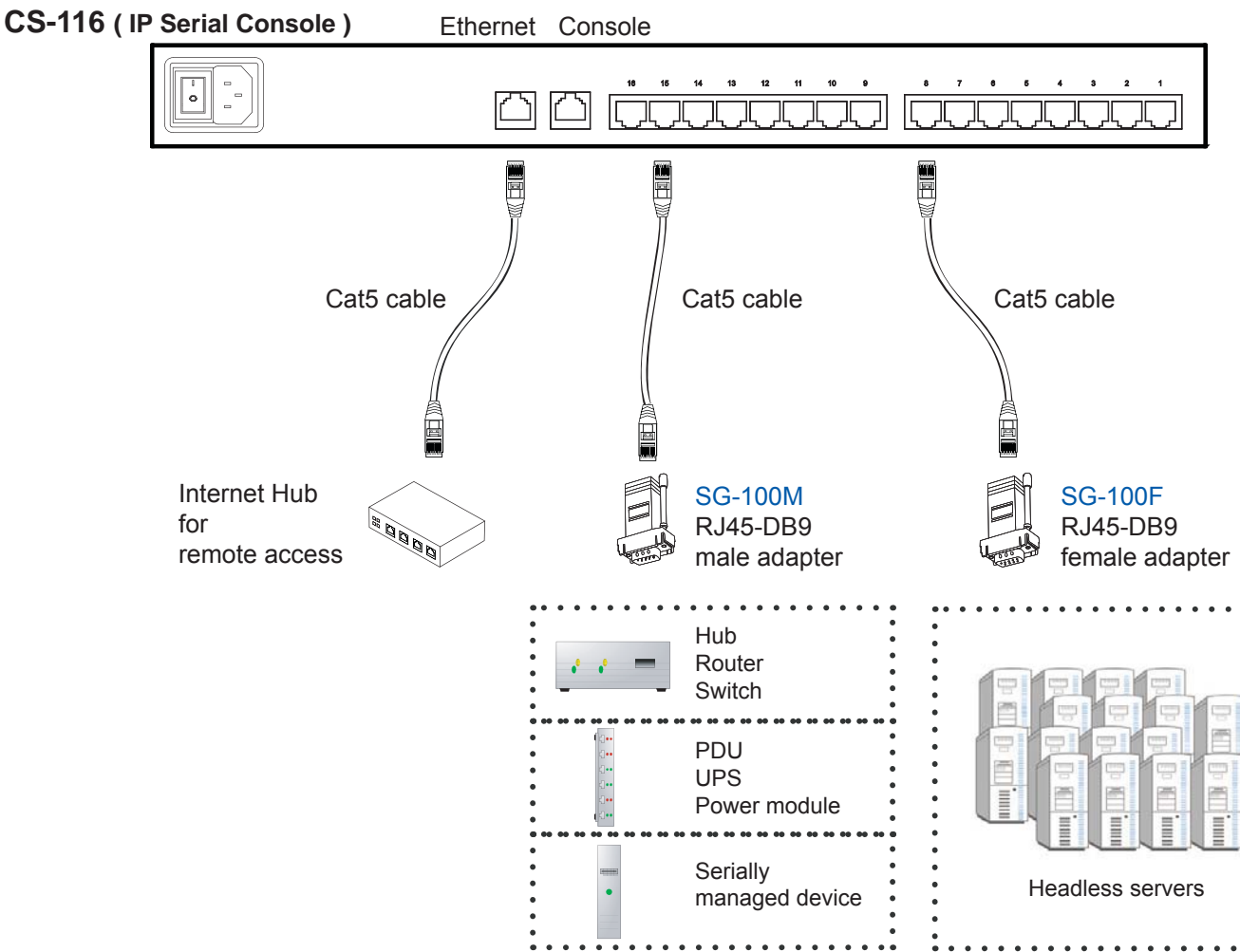
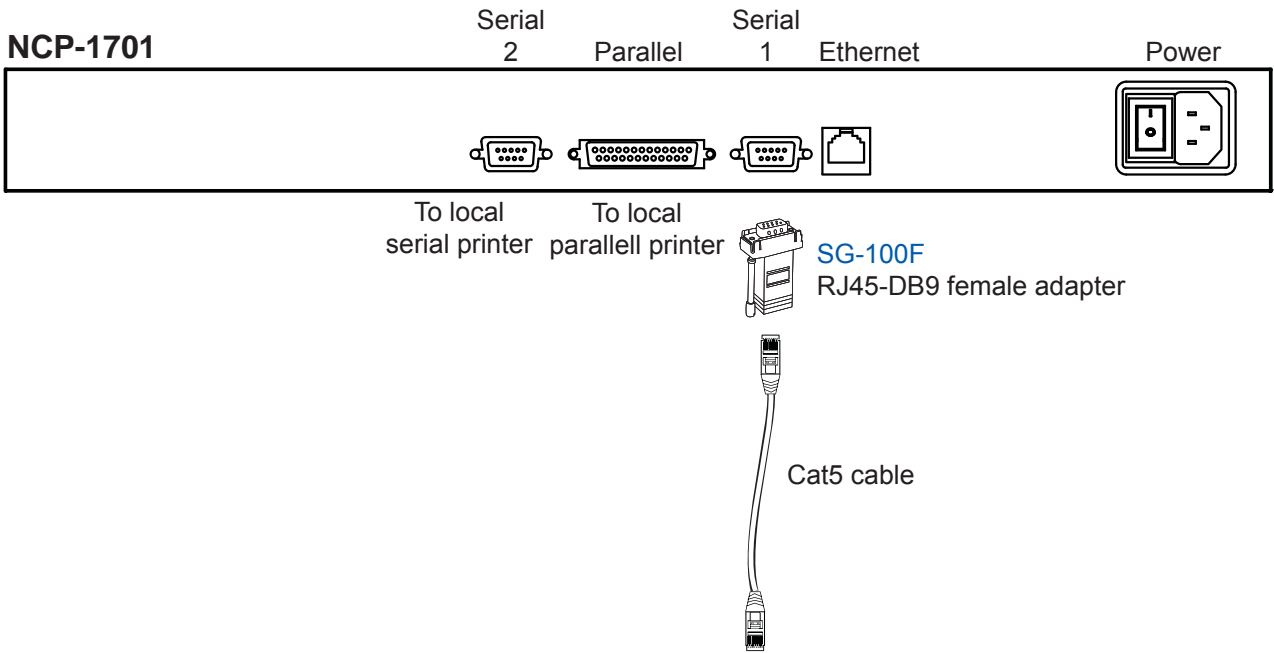

Switch on the power on the rear of NCP-1701.

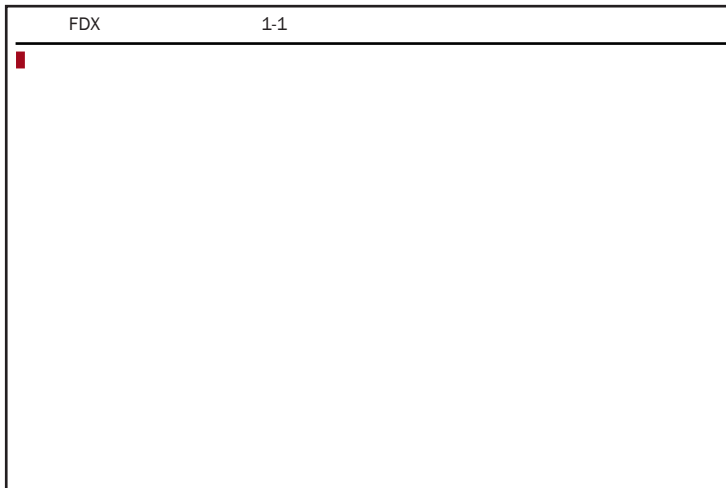

Entering SETUP

Hold down the **Alt** key and then depress the **Esc** key to enter SETUP mode.

When you enter SETUP mode, any text on the screen temporarily disappears, and the main SETUP directory appears. When you leave the SETUP mode, the main SETUP directory disappears, and any text that was on the screen reappears.

Caution: Scroll lock must be off for accessing setup menu by “Alt + Esc” key

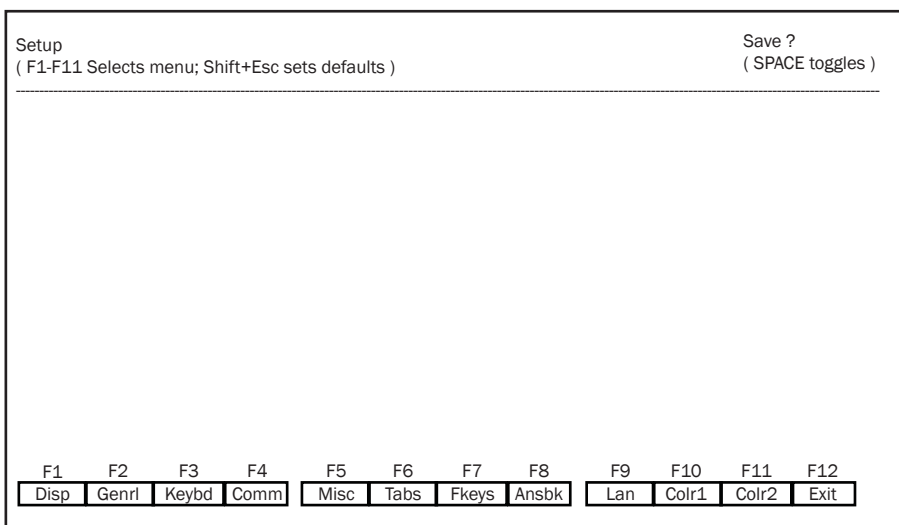

Saving and exiting SETUP

The first menu seen when entering SETUP mode serves as a directory to the other SETUP menus. When you depress **F12** to exit Setup, you will return to this main directory and be given the option of saving your selections.

The highlighted field at the right of the screen gives you the choice of saving or not saving parameter changes in the nonvolatile memory before returning the terminal to the normal operating mode. If you don't save your setting before you leave the SETUP mode, any new selections will be lost when you power down the console terminal drawer.

To save your SETUP selection, depress the **Spacebar** to change the save field at the right side of the screen from **NO** to **YES** before exiting SETUP.

Depress **F12** to exit SETUP mode and return to the normal display mode.

To select one of the setup menu's shown, press the indicated function key.

- The screen for that menu appears with the name highlighted.
- The fields in the middle of the screen, indicate the parameters that you can change in that menu.
- The top line identifies the keys you press to highlight the parameter fields and change the settings. The procedure is:

(1) Use arrow key to highlight the parameter field you want to change.

(2) Use the Spacebar to change the parameter.

F12 always returns you to the top menu.

The following tables list the parameters for each menu and explains their settings.

Default settings are listed first unless otherwise noted.

F1 Display Setup Menu

Columns	Sets the screen display for 80 columns, 132 columns, or Econ-80. (80 columns with more pages of memory)
Lines	Sets the screen display for 24, 25, 42, or 43 lines. (25 lines is normally required for PC Term.)
Page Length	Sets the length of a page of display memory to: 1 x Lines: Equal to the number of lines selected in the lines parameter 2 x Lines: Two times the value of the lines parameter 4 x Lines: Four times the value of the lines parameter, or *Equal to the value of the lines parameter, with a second page containing the rest of the lines remaining in memory.
Cursor	Sets the cursor display to blink or steady, block or underline.
Background	Sets the screen display to Dark (light characters on a dark background) or Light (dark characters on a light background).
Auto Page	Cuses a new page of memory to move onto the screen when the cursor reaches the top or bottom of the page.
Screen Saver	Off, 1, 2, 3, 4, 5, 6, means no saver, 5, 10, minutes saver.
Width Change Clear	Causes the terminal to clear the screen when executing a command to change the number of columns.
Reverse	Off / On control function ANSI, VT-100 and VT-220: "Off" means, when SGR command ESC [3? m and ESC [4? m select background and foreground color change respectively. "On" means, when SGR command ESC [3? m and ESC [4? m select foreground and background color change respectively. (? can be 0,1,2,...,7)
Display	CRT/LCD chose which kind of monitor be used. If LCD monitor be selected, the display columns only support 80 columns on Econ-80 columns.

F2 General SETUP Menu

Personality	Sets the terminal's operating mode to Wyse 325, Wyse 120/Wyse 60 (native mode), Wyse 50+ (WY-50, WY-50+, WY-100, ADM 31/5/3a), TeleVideo TVI 925, TVI910+ (includes 910), ADDS A2, Digital Equipment VT-100, VT-220 7 bits, VT-220 8 bits, VT-52, Console ANSI, PC TERM, PCG Alpha.
Scroll Speed	Sets the display scroll rate to Jump (the rate data is received), Smooth-8 (eight lines per second), Smooth-4, Smooth-2, or Smooth-1.
Rcvd CR	Causes the cursor to move to the beginning of the current line (CR) or the beginning of the next line (CRLF) when the terminal receives an ASCII CR.
Enhance	Allows the terminal to recognize an enhanced set of codes when the terminal is not in the native personality.
Auto Scroll	Causes the data to scroll up a line when the cursor moves past the last line of the page.
Monitor	Causes the terminal to display symbols for escape sequences and control codes without acting on them. (Test Feature)
Status Line	Sets the top line of the screen as the status line.
End of Line Warp	Causes the cursor to move to the start of the next line when additional characters are entered at the end of a line.
Attribute	Sets display attributes to be assigned to each character as it is entered (Char), to be active to the end of the line (Line), or to be active to the end of the page (Page).

F3 Keybd SETUP Menu

Xmt Limit	Causes the terminal to send data through the HOST port as fast as the baud rate allows (None), or at a maximum rate of 60 cps or 150 cps. In older systems limiting character-rate is necessary to prevent loss of data.
Language	Sets correct terminal operation for the language of the keyboard connected to it: US, UK, Danish, German, Spanish, Swedish, Norwegian, Italian, French, Belgian, Swiss/French, and Swiss/German.
Key Repeat	Off, 1, ..., 8 8 different repeat rates after a key has been depressed for about 1/2 seconds.
Margain Bell	Sets the terminal's bell to ring when the cursor reaches the column where the bell is set (default is column 72 in 80-column mode or 124 in 132-column mode).
Keycode	Sets the terminal to send normal ASCII characters (ASCII) or PC-type scan codes for every key up / down (Scan). Scan is required for the PC Term personality.
Keyclick	Sets the terminal to sound a muted beep each time a key is pressed or repeated.
NRC	Sets the terminal to have national replacement character functional.
Bell Volumn	Off, 1, 2, 3 (3 different volume)
Num Start	Off / On when the terminal power on, this field determines whether the numeric pad starts as Numeric (NUM On) or Function (NUM Off).

F4 Comm SETUP Menu

Baud Rate	Sets the host port baud rate to 50, 110, 134.5, 200, 300, 600, 1200, 2400, 4800, 7200, 9600, 19200, 38400, 57600, 76800, or 115200.
Rcv Hndshake	Allows the terminal to control the receipt of data from a device connected to the SERIAL1 port with no handshaking (None), Xon / Xoff handshaking, DTR handshaking, DTR / Xoff handshaking, or by sending special codes (XPC). XPC is possible only when the personality parameter is set to PC Term.
Data / Stop Bits	Through the SERIAL1 port, the terminal to send and receive 8-bits data with one stop bit or two stop bits, or 7-bits data with one stop or two stops bits.
Xmt Hndshake	Xmt Hndshake causes the terminal, when sending data to a device connected to the SERIAL1 port, to ignore all incoming software hand-shaking signals (None) or to control data output in responds to Xon/Xoff handshaking.
Parity	Causes the terminal send the data to the SERIAL1 port with none, odd, mark, even, or space parity.
Comm Mode	Sets the SERIAL1 port communication mode to full duplex (FDX), block (BLK), half duplex (HDX), or half-duplex block (HBLK).
	Printer Selection
	Parallel : Sends data to a parallel printer connected to the parallel port.
	Serial : Sends data to a serial printer connected to the serial 2 port.
	Off : Ignores the print command.
Ethernet Mode	On/off to set the communication routing by Ethernet Network / or Serial Port.
Multiple Sessions	Defines Ethernet terminal have multiple sessions function.
	On : Indicates the terminal has multiple sessions function, but each session only has one page display. In 80 or 132 column mode, 4 sessions simultaneously. In Econ-80 column mode, 7 sessions simultaneously.
	Off : Indicates the terminal only has single session, but it has multiple pages display.

F5 Misc SETUP Menu

Wprt Intensity	Normal, blank , dim, blank/dim.
Block End	Causes the terminal to send a block of data to the computer with a line terminator as an ASCII US character and block terminator as an ASCII CR character (US / CR), or with line terminators as ASCII CR and LF characters and the block terminator as an ASCII ETX character (CRLF / ETX).
Wprt Reverse	Sets the write-protected characters to appear in reverse (dark characters on a light background).
Wprt Underline	Sets the write-protected characters to appear underlined.
Ptr Baud Rate	Sets the SERIAL 2 port baud rate to 75, 150, 300, 600, 1200, 2400, 4800, 7200, 9600, 19200, 38400, 57600, 76800, 115200, 230400, 460800.
Ptr Data / Stop Bits	Through the SERIAL 2 port ,the terminal to send and receive 8-bits data with one stop bit or two stop bits, or 7-bits data with one stop or two stops bits.
Ptr Parity	Causes the terminal to send the data to the SERIAL 2 port with none, odd, mark, even, or space parity.
Ptr Xmt Hndshake	None, DSR, Xon / Xoff, Both .
Ptr Rcv Hndshake	None, DTR, Xon / Xoff, DTR/Xoff .

F6 Tabs Setup Menu

On the tabs setup menu screen, the terminal's current tab stops are indicated by uppercase T's displayed along a line of periods that mark each column position.

- (1) A tab stop in columns 2 through 78 is shown as a T in the upper line of periods
- (2) A tab stop in columns 79 through 132 is shown as a T in the lower line of periods

You can easily determine where tabs are set by moving the cursor across the line and reading the column number displayed on the right side of the screen.

Clear and set tabs anywhere on the line, as follows:

- (1) To move the cursor across the line, press **←** or **→**
- (2) To either clear or set (toggle) an individual tab stop at the cursor position, press **Spacebar**
- (3) To clear all tabs, press **Home**
- (4) To set tabs to the default setting (every eighth column), press **Backspace**

Note: A tab stop cannot be set to column 1.

F7 FKeys SET-UP Definition Setup Menu

You can redefine the function keys and many of the editing keys to send a unique character string of up to 64 characters. Keys that are not programmed will send a default sequence which is determined by the personality selected. Below table lists the programmable keys.

To redefine a key:

- 1. Select the key to be redefined by pressing that key together with **Ctrl**. This highlights the key's definition field.
- 2. Press **↑** to select the shifted or unshifted key definition field.
- 3. Enter the key definition (up to 62 characters) at the cursor position. Correct errors by pressing **←** to delete characters or **Home** to clear the definition.
- 4. If you want to change the key's direction, press **Enter** (on the numeric pad) until your choice appears.

Direction determines where the key data is transmitted:



- Remote : Sends data to the computer only, regardless of the terminal's communication mode. (Until redefined, the direction of all the programmable keys is remote.)
- Local : Sends data to the terminal only, regardless of the terminal's communication mode
- Normal : Sends data to the computer and / or the terminal, depending on the terminal's communication mode

Programmable Keys

Enhanced PC-Style Keyboard	Enhanced Pc-Style Keyboard
F1 through F12	*ENTER
Arrow Key ↑	ESCAPE
Arrow Key ↓	HOME
Arrow Key →	INSERT
Arrow Key ←	PAGE DOWN
BACKSPACE	PAGE UP
DELETE	PRINT SCREEN
END	TAB

*Both **ENTER** keys are programmable

F8 Ansbk SET-UP Menu

You can program a message of up to 20 characters to identify the terminal to the computer. Enter the message at the cursor position. Correct errors by pressing  to delete characters or  to clear the message.

CONCEAL hides the answerback message, so it is not displayed in SETUP mode.

To save the message in nonvolatile memory, exit SETUP mode with the YES option.

F9 Lan Setup Menu

This menu allows the terminal setup for Ethernet communication. Use of Ethernet communications provides the additional ability to open multiple sessions (applications) on one or more hosts/servers at the same time. Support of these extended features requires the creation of special files at the host computer(s) by the MIX manager for your system. The settings selected by the MIX at the host(s) must also be entered in this menu for proper communications.

Note: The Ethernet option in the F4 setup menu must be set to ON for the terminal to work in an Ethernet environment.

Ethernet Node ID:	Displays the serial number of the hardware Ethernet interface device. This is a default value of the manufacturer of the hardware device and should not be changed.
Local IP Address:	The IP address assigned to this terminal by the MIS manager. Each terminal must have a unique IP address. The address is used to allow the host to identify messages from this terminal and to allow the terminal to filter out return messages from the common Ethernet cable. An example of this address is 192.168.123.211.
Netmask:	The value generated by the system based on the IP address. The system administrator would have this information. An example is 255.255.255.0
Remote IP 0...B Address:	For any remote host, or devices, that the terminal will communicate with for a specific session. These twelve remote IP addresses should all be identical if all communications will be with only one host. If Multisession ON in the F4 menu has been selected, and here is more than one host on your system, you must specify which host each session will communicate with. To communicate with a different host for a future session, these settings be changed.
	Note: The Multisession option allows 4 separate sessions if any emulation other than ECON-80 is selected. If ECON-80 emulation is selected, the Multisession option allows 7 separate sessions.
Gateway:	This IP address is used to communicate with other networks. If a gateway is not being used this option should be blank.
Term Type:	Allows definition of the terminal with up to 40 characters. If Term Type is empty the default type is sent to the host by the system

F10 Color Set-up Menu

The color functionality differs with emulation.

In general VT100, VT220 and ANSI Console work with applications which control the color directly. The remaining personalities associate colors based on existing monochrome video attributes.

This section will define parameter selection based on personality selected.

Background Will determine the color of the background screen under some conditions (16 colors).

Cursor: Select the color of the cursor (16 colors).

Normal F.G. / Normal B.G.: These fields allow you to select the character and background color (16 colors) for data entered on the display before your application defines the color display remotely.

Intensity F.G. Intensity B.G.: These fields allow you to select the character and background color (16 colors) for data entered on the display as Dim in ASCII emulation's and Bold in VT\ANSI emulation's before your application defines the color display remotely.

Color Mode: Is automatically selected based on your emulation selected.

Color Map: Applies in WY325 mode only and determines if the monochrome attribute Reverse or Blank will be used to map monochrome attributes to color.

	ASCII (NOT WY325)	WY325*	VTXXX	ANSI CONSOLE
Background	The whole data area of the screen will be displayed in this color, when the application hasn't entered character or spaces with the Normal or Intensity B.G. color. Changes in Background color will affect Normal and Intensity B.G. Any clear screen commands will clear to this color.	No Function	Same as ASCII	Same as ASCII
Cursor	Selects Cursor color	Selects Cursor color	Selects Cursor color	Selects Cursor color
Normal F.G.	Selects color of Normal F.G.	No Function	Initial color selection at power up	Initial color selection at power up
Normal B.G.	Selects color of Normal B.G.	No Function	Initial color selection at power up	Initial color selection at power up
Intensity F.G.	Selects color of Intensity F.G.	No Function	Initial color selection at power up	Initial color selection at power up
Intensity B.G.	Selects color of Intensity B.G.	No Function	Initial color selection at power up	Initial color selection at power up
Color Mode (Normal/ Palette)	Automatic	Automatic	Automatic	Automatic
Color Map (Reverse/Blank)	No Function	See Above	No Function	No Function

* When the WY 325 personality is selected holding the Ctrl key down and depressing either the 0, 1, ..., 9 or (.) period keys in the numeric pad change the assignment of color on the screen. Each selection is called a palette and is described in Color Palette Table

Color Palettes

Palette	Display Attribute	Foreground Color	BackGround Color
0	Normal Reverse (or blank)*1 Intensity*2 Intensity*2 and reverse (or blank)*1 Underline Underline and reverse (or blank)*1 Underline and intensity*2,*3 Underline, intensity,*2 and reverse (or blank)*1	Green Black Blue Black Cyan Black Red Black	Black Yellow Black Blue Black Cyan Black Red
1	Normal Reverse (or blank)*1 Intensity*2 Intensity*2 and reverse (or blank)*1 Underline Underline and reverse (or blank)*1 Underline and intensity*2,*3 Underline, intensity,*2 and reverse (or blank)*1	Green Black Yellow Black Cyan Black White Black	Black Red Black Yellow Black Cyan Black White
2	Normal Reverse (or blank)*1 Intensity*2 Intensity*2 and reverse (or blank)*1 Underline Underline and reverse (or blank)*1 Underline and intensity*2,*3 Underline, intensity,*2 and reverse (or blank)*1	Cyan Black Red Black Magenta Black Blue Black	Black White Black Red Black Magenta Black Blue
3	Normal Reverse (or blank)*1 Intensity*2 Intensity*2 and reverse (or blank)*1 Underline Underline and reverse (or blank)*1 Underline and intensity*2,*3 Underline, intensity,*2 and reverse (or blank)*1	Cyan Black White Black Magenta Black Yellow Black	Black Blue Black White Black Magenta Black Yellow
4	Normal Reverse (or blank)*1 Intensity*2 Intensity*2 and reverse (or blank)*1 Underline Underline and reverse (or blank)*1 Underline and intensity*2,*3 Underline, intensity,*2 and reverse (or blank)*1	Magenta Black Blue Black Green Black Red Black	Black Cyan Black Blue Black Green Black Red
5	Normal Reverse (or blank)*1 Intensity*2 Intensity*2 and reverse (or blank)*1 Underline Underline and reverse (or blank)*1 Underline and intensity*2,*3 Underline, intensity,*2 and reverse (or blank)*1	Magenta Black White Black Green Black Cyan Black	Black Yellow Black White Black Green Black Cyan
6	Normal Reverse (or blank)*1 Intensity*2 Intensity*2 and reverse (or blank)*1 Underline Underline and reverse (or blank)*1 Underline and intensity*2,*3 Underline, intensity,*2 and reverse (or blank)*1	Yellow Black Red Black Cyan Black Magenta Black	Black Yellow Black Red Black Cyan Black Magenta

Color Palettes

Palette	Display Attribute	Foreground Color	BackGround Color
7	Normal Reverse (or blank)*1 Intensity*2 Intensity*2 and reverse (or blank)*1 Underline Underline and reverse (or blank)*1 Underline and intensity*2,*3 Underline, intensity,*2 and reverse (or blank)*1	Red Yellow Magenta Black Cyan Black Green Black	Black Red Black Magenta Black Cyan Black Green
8	Normal Reverse (or blank)*1 Intensity*2 Intensity*2 and reverse (or blank)*1 Underline Underline and reverse (or blank)*1 Underline and intensity*2,*3 Underline, intensity,*2 and reverse (or blank)*1	White Black Red Black Yellow Black Magenta Black	Black White Black Red Black Yellow Black Magenta
9	Normal Reverse (or blank)*1 Intensity*2 Intensity*2 and reverse (or blank)*1 Underline Underline and reverse (or blank)*1 Underline and intensity*2,*3 Underline, intensity,*2 and reverse (or blank)*1	White Black Yellow Black Blue Black Cyan Black	Black White Black Yellow Black Blue Black Cyan
10 (Soft Palette)	Normal Reverse (or blank)*1 Intensity*2 Intensity*2 and reverse (or blank)*1 Underline Underline and reverse (or blank)*1 Underline and intensity*2,*3 Underline, intensity,*2 and reverse (or blank)*1	Green Black Blue Black Cyan Black Red Black	Black Yellow Black Blue Black Cyan Black Red

- *1. Whether the reverse or blank attribute is mapped to the colors shown depends on an escape sequence or the setting of the Color Map setup parameter on the Attribute menu. The default is reverse. When the blank attribute is mapped, only the background is visible.
- *2. The intensity is dim in ASCII personalities and bold in ANSI personalities. (The intensity attribute is not supported in the following personalities: Wyse 50+, ADDS A2, TVI 910+, TVI925, and VT52.) The attribute can be disabled by an escape sequence or in setup mode (Intensity Attribute parameter).
- *3. In each palette, the status line displays the same foreground and background colors as shown here for the underline-and-intensity attribute.

Commands	Key Sequence by Keyboard Style Enhanced PC
Toggle CAPS LOCK on/off	CAPS LOCK
Toggle NUM LOCK on/off	NUM LOCK
Put terminal in SETUP mode	ALT ESC
Partially reset terminal, including communication unlock keyboard, turn off all print modes.	ALT PAUSE
Send break* ¹	BREAK* ²
Toggle between block and full-duplex modes	SHIFT BREAK
Print Screen formatted	PRINT SCREEN
Turn auxiliary print mode on/off	SHIFT SYS REQ* ³
Turn monitor mode on/off	CTRL SHIFT 1 (kpd)
Turn status line display on/off	CTRL
Speed scrolling rate	CTRL SHIFT
Slow scrolling rate	CTRL SHIFT
Home cursor and clear page	CTRL SHIFT HOME
Display page 0	CTRL 0kpd
Display page 1	CTRL 1kpd
Display next page (or active other window)* ⁴	PAGE DOWN
Display previous page (or active other window)* ⁵	PAGE UP
Toggle between split screen* ⁵ and full screen format	CTRL SHIFT -kpd
Toggle Session 0* ⁶	ALT F1
Toggle Session 1* ⁶	ALT F2
Toggle Session 2* ⁶	ALT F3
Toggle Session 3* ⁶	ALT F4
Toggle Session 4* ⁶	ALT F5
Toggle Session 5* ⁶	ALT F6
Toggle Session 6* ⁶	ALT F7
Toggle Session 7* ⁶	ALT F8
Toggle Session 8* ⁶	ALT F9
Toggle Session 9* ⁶	ALT F10
Toggle Session A* ⁶	ALT F11
Toggle Session B* ⁶	ALT F12
Close the active Session by Local Terminal* ⁶	CTRL SHIFT . kpd

*1. To MODEM port only when configured as data port: has no effect on AUX port.

*2. [BREAK] = [PAUSE] pressed together with [CTRL].

*3. [SYS REQ] = [PRINT SCREEN] pressed together with [CTRL].

*4. If screen is split.

*5. Splits screen at line 12.

*6. Only active at Ethernet mode on.

Serial Port (Serial 1) Connector Pin Assignments (RS232C 9-Pin connector)

Pin	Signal	Mnemonic	Direction
1	Data carrier detect	DCD	In
2	Receive data	R x D	In
3	Transmit data	T x D	Out
4	Data terminal ready	DTR	Out
5	Signal ground	SGND	
6	Data set ready	DSR	In
7	Request to send	RTS	Out
8	Clear to send	CTS	In

Serial printer Port (Serial 2) Connector Pin Assignments (RS232C 9-Pin connector)

Pin	Signal	Mnemonic	Direction
1	Data carrier detect	DCD	In
2	Receive data	RxD	In
3	Transmit data	TxD	Out
4	Data terminal ready	DTR	Out
5	Signal ground	SGND	
6	Data set ready	DSR	In
7	Request to send	RTS	Out
8	Clear to send	CTS	In

Printer Port Connector Pin Assignments (Compatible with the IBM PC parallel port)

Pin	Signal	Mnemonic	Direction
1	-Strobe		Out
2	Data bit 0		Out
3	Data bit 1		Out
4	Data bit 2		Out
5	Data bit 3		Out
6	Data bit 4		Out
7	Data bit 5		Out
8	Data bit 6		Out
9	Data bit 7		Out
10	-Acknowledge		In
11	Busy		In
12	Paper end		In
13	Slct		In
14	-Auto feed XT		Out
15	-Error		In
16	-Init		Out
17	-Slctn		Out
18-25	Ground		Out

10BaseT connector Pin Assignment (RJ-45 8 pin phone jack connector)

Pin	Signal	Direction
1	Transmit +	Out
2	Transmit -	Out
3	Receive +	In
4	Receive -	In

Commands Supported in ASCII Personalities

Below table lists all the ASCII commands recognized by the terminal. The native mode code for the command is given in the second column. (The native mode include WY-325,WY-120 and WY-60.) The remaining columns show the support for the command in other ASCII personalities according to the following notations:

- Same -** Same as native code (code is native to other terminal also)
- Wyse -** Same as native code (Wyse enhancement- code not native to other terminal)
- ENH -** Same as native code when enhance mode is on (Wyse enhancement - code not native to other terminal)

A code listed under a nonnative personality indicates that the related terminal's native code is supported. A blank in any column indicates that the command is not supported.

Variables are shown in italics. Their values are listed in alphabetical order at the end of the table.

Commands Supported in ASCII personalities

FUNCTION	Command				
	Native Mode	Wyse WY-50+	ADDS VP A2	TVI 910+/925	PC Term
Monitor Mode					
Monitor mode on	ESC U	Same		Same	Same
Monitor mode off	ESC u or ESC X	Same		Same	Same
Selecting Personalities					
Enhance mode off	ESC ~ SPACE	Same	ENH	ENH	ESC v SPACE
Enhance mode on	ESC ~ !	Same	ENH	ENH	ESC v !
Select WY-50+ mode	ESC ~"	Same	ENH	Wyse	ESC v "
Select TVI 910+ mode	ESC ~ #	Same	ENH	Wyse	ESC v #
Select TVI 925 mode	ESC ~ \$	Same	ENH	Wyse	ESC v \$
Select ADDS VP A2 mode	ESC ~ %	Same	ENH	Wyse	ESC v %
Select Console ANSI mode	ESC ~ A	Same	ENH	Wyse	ESC v A
Select Native mode	ESC ~ 4	Same	ENH	Wyse	ESC v 4
Select PC Term mode	ESC ~ 5	Same	ENH	Wyse	ESC v 5
Select VT52 mode	ESC ~ 6	Same	ENH	Wyse	ESC v 6
Select VT100 mode	ESC ~ ;	Same	ENH	Wyse	ESC v ;
Select PCGRAPHIC mode*1	ESC ~ I	Same	ENH	Wyse	ESC v I
Select VT220-7 mode	ESC ~ <	Same	ENH	Wyse	ESC v <
Select VT220-8 mode	ESC ~ =	Same	ENH	Wyse	ESC v =
Select WY-325 mode*3	ESC ~ B	Same	ENH	Wyse	ESC v B
Communicating with the computer					
Enable transmission	CTRL Q	Same	Same	Same	Same
Stop transmission Disconnect	CTRL S	Same	Same	Same	Same
Send ACK (if ACK mode on)	CTRL E	Same		Wyse	Same

Commands Supported in ASCII personalities, Continued

FUNCTION	Command				
	Native Mode	Wyse WY-50+	ADDS VP A2	TVI 910+/925	PC Term
ACK mode off	ESC e 6	Same		ENH	
ACK mode on	ESC e 7	Same		ENH	
Full-duplex mode on	ESC C ESC D F	Same		Same	ESC }
Half-duplex mode on	ESC C ESC D H	Same		Same	ESC {
Block mode on	ESC B	Same		Same	Same
Block mode off (conversation)					ESC C
Half-duplex block mode on	ESC D H ESC B	Same		Same	ENH
Set Serial 1 port receive handshaking protocol	ESC c 2 hndshk	Same	ENH		
Set Serial 1 port transmit handshaking protocol	ESC c 4 hndshk	Same	ENH		
Set maximum data transmission speed for host port	ESC c 6 max				
Set Serial 1 port operating parameters	ESC c 0 baud stop parity word				
Set Serial 2 port operating parameters	ESC c 1 baud stop parity word				
Enable DTR Serial port 1 handshaking			CTRL N	CTRL N	CTRL N
Enable X-on/X-off Serial port 1			CTRL O	CTRL O	CTRL O
Program answerback message	ESC c; answer CTRL Y		Same	ENH	
Conceal answerback message	ESC c =	Same	ENH		
Send answerback message	ESC c <	Same	ENH		
Turn answerback mode off	ESC e SP	Same	ENH		
Turn answerback mode on	ESC e !	Same	ENH		

Contolling the Terminal and keyboard

Sound bell	CTRL G	Same	Same	Same	Same
Select bell volume	ESC c \volume	Same	ENH		
Unlock keyboard	CTRL N or ESC"	Same	CTRL B	ESC "	ESC "
Lock keyboard	CTRL O or ESC#	Same	CTRL D	Same	ESC #
CAPS LOCK off	ESC e '	ENH	ENH	ENH	ESC SP M
CAPS LOCK on	ESC e &	ENH	ENH	ENH	ESC SP L
NUM LOCK off	ESC e @	ENH	ENH	ENH	ESC SP K
NUM LOCK on	ESC e A	ENH	ENH	ENH	ESC SP J
SCROLL LOCK off	ESC e B	ENH	ENH	ENH	ESC SP O
SCROLL LOCK on	ESC e C	ENH	ENH	ENH	ESC SP N
Keyclick off	ESC e \$	Same	ENH	ESC <	ESC <
Keyclick on	ESC e %	Same	ENH	ESC >	ESC >
Margin bell off	ESC e L	Same	ENH	ENH	ESC n
Margin bell on	ESC e M	Same	ENH	ENH	ESC o
Set margin bell at curs position	ESC ' J	Same	ENH		
Select standard ASCII key code mode	ESC e H	Same	ENH		
Select PC scan code mode	ESC e I	Same	ENH		
Key repeat off	ESC e ,	Same	ENH	ENH	
Key repeat on	ESC e -	Same	ENH	ENH	
Read keyboard status					ESC [

Commands Supported in ASCII personalities, Continued

FUNCTION	Command				
	Native Mode	Wyse WY-50+	ADDS VP A2	TVI 910+/925	PC Term
Redefining the keys					
Clear function key definition	ESC z fkey DEL	Same			
Clear key direction and definition	ESC Z dir key/fkey DEL	Same	ENH		
Program function key definition	ESC z fkey sequence DEL	Same	ENH	ENH	
Program key direction and definition	ESC Z dir key/fkey sequence DEL	Same		Wyse	ESC p1 p2 sequence CTRL Y
Read key direction and definition	ESC Z ~key or ESC Z ~fkey	Same			
Screen and Cursor Display					
Screen display off	ESC ` 8	Same	ENH	ESC o	ESC O
Screen display on	ESC ` 9	Same	ENH	ESC n	ESC N
Screen saver off	ESC e P	Same	ENH	ENH	
Screen saver on	ESC e Q	Same	ENH	ENH	
Set reverse screen	ESC ^ 1	Same	ENH	ESC b	
Restore normal screen	ESC ^ 0	Same	ENH	ESC d*4	
Set scrolling speed and type	ESC ` scroll	Same	ENH		
Smooth scrolling on				ESC 8*5	
Smooth scrolling off				ESC 9*5	
Set cursor display features	ESC ` cursor	Same	ENH	ESC . cursor1	ESC . cursor1
Cursor display off	ESC ` 0	Same	CTRL W		
Cursor display on	ESC ` 1	Same	CTRL X		
25th line display off					ESC e
Displaying the Message Fields					
Extended status line on	ESC ` a	Same	ENH		
Standard status line on	ESC ` b	Same	ENH		
Status line off	ESC ` c	Same	ENH		
Program/display computer message on status line	ESC F message CR	Same	ENH		
Program computer message on unshifted label line*6	ESC z (text CR	Same	ENH	ESC f*5 text CR	ESC f text CR
Program computer message on shifted label line	ESC z) text CR	Same	ENH		
Turn off shifted label line	ESC z DEL	Same	ENH	ENH	
Clear unshifted label line	ESC z (CR	Same	ENH		
Clear shifted label line	ESC z) CR	Same	ENH	ENH	
Program/display function key label	ESC z field label CR	Same	ENH	ENH	
Clear function key label	ESC z field CR	Same	ENH	ENH	

Commands Supported in ASCII personalities, Continued

FUNCTION	Command				
	Native Mode	Wyse WY-50+	ADDS VP A2	TVI 910+/925	PC Term
Defining the data Area					
Select 80-column display	ESC ` :	Same	ENH		
Select 132-column display	ESC ` ;	Same	ENH		
Economy 80-column mode off	ESC e F	Same	ENH		
Economy 80-column mode on	ESC e G	Same	ENH		
Width-change-clear mode off	ESC e .	Same	ENH		
Width-change-clear mode on	ESC e /	Same	ENH		
Display 24 data lines*7	ESC e (Same	ENH		
Display 25 data lines*7	ESC e)	Same	ENH		ESC ^
Display Memory/Split Screen					
Divide memory into pages	ESC w length	Same	ENH		
Display previous page	ESC w B or ESC J*8	Same	ENH	ESC J	
Display next page	ESC w C or or ESC K*8	Same	ENH	ESC K	
Display page n	ESC w page	Same	ENH		
Split screen horizontally (simple split)	ESC x A line	Same			
Split screen horizontally (simple split) and clear pages	ESC x 1 line	Same			
Split screen horizontally (adjustable split) and clear pages	ESC x 3 line	Same			
Split screen horizontally (adjustable split)	ESC x C line	Same			
Activate upper window	ESC]	Same			
Activate lower window	ESC }	Same			
Activats other window (or page *8)	ESC J or ESC K	Same	ESC J*5		
Lower horizontal split	ESC x P	Same			
Raise horizontal split	ESC x R	Same			
Roll window up in page	ESC w E	Same			
Roll window down in page	ESC w F	Same			
Redefine screen as one window	ESC x @	Same			
Redefine screen as one window and clear pages	ESC x 0	Same			
Display Attributes					
Assign display attribute to a message field	ESC A mf attr	Same	ESC *4		
Assign character display attribute	ESC G attr	Same	ENH	Same	Same
Character attribute mode off	ESC e 0				
Character attribute mode on	ESC e 1				
Page attribute mode on	ESC e 2	Same			
Line attribute mode on	ESC e 3	Same			
Assign write-protected character display attribute	ESC ` wpca	Same	ESC 0 wpca1		
Clear unprotected page to display attribute	ESC !	ENH	Wyse attr		
Assign line attribute	ESC G lattr	Same	ENH		
Redefine color map values*9	ESC d y fcolor bcolor map				

Commands Supported in ASCII personalities, Continued

FUNCTION	Command				
	Native Mode	Wyse WY-50+	ADDS VP A2	TVI 910+/925	PC Term
Set tag protect attribute			CTRL N		
Reset tag protect attribute			CTRL O		
Select a predefined color palette*9	ESC d z palette				
Map blank attribute*9	ESC d {				
Map reverse attribute*9	ESC d				
Protecting Data					
Write-protect mode off	ESC (Same	CTRL O	Same	Same
Write-protect mode on	ESC)	Same	CTRL N	Same	Same
Clear cursor column to write-protected spaces	ESC V	Same	ENH	Same	
Protect mode off	ESC ,	Same	ENH	Same	Same
Protect mode on	ESC &	Same	ENH	Wyse	Same
Graphics Characters					
Graphics mode on	ESC H CTRL B	Same	ESC \$	ESC \$	
Graphics mode off	ESC H CTRL C	Same	ESC %	ESC %	
Display graphics character	ESC H ldraw	Same			
Controlling the Cursor					
Cursor left (backspace)	CTRL H	Same	Same	Same or CTRL U	Same
Cursor right	CTRL L	Same	CTRL F	Same	Same
Cursor up; no scroll	CTRL K	Same	CTRL Z	Same	Same
Cursor up; scroll (reverse linefeed)	ESC j	Same	ENH	Same*10	Same
Cursor down; no scroll				CTRL V	CTRL V
Cursor down; scroll (Linefeed)	CTRL J	Same	Same	Same	Same
Cursor to start of line	CTRL M	Same	Same	Same	Same
Cursor to start of next line	CTRL _	Same	ENH	Same	Same
Home cursor	ESC { or CTRL ^	Same	ENH or CTRL A	Wyse Same	CTRL ^
Cursor to specific column			CTRL P col	ESC]*11	
Cursor to specific line			CTRL K line	ESC [
End-of-line wrap off	ESC d .	Same	ENH		ESC 0
End-of line wrap on	ESC d /	Same	ENH		ESC ~
Received CR mode off	ESC e 4	Same	ENH	ENH	ESC 9
Received CR mode on	ESC e 5	Same	ENH	ENH	ESC 8
Autopage mode off	ESC d *	Same	ENH	ESC w	
Autopage mode on	ESC d +	Same	ENH	ESC v	
Autoscrolling mode off	ESC N	Same	ENH		
Autoscrolling mode on	ESC O	Same	ENH		
Address cursor in current 80-column page	ESC = line col	Same	ENH or ESC Y	Same	Same
Address cursor in specific 80-column page	ESC w @ page line col	Same	ENH	ESC - page line col	
Address cursor in specific 80-column window/page*8	ESC - wnd/page line col	Same	ENH		Same
Address cursor in specific 80/132-column current page	ESC a III R ccc C	Same	ENH		Same
Read cursor line and column address in 80-column current page	ESC ?	Same	ENH	Same	Same
Read 80-column page number and cursor address	ESC w `	Same	ENH		

Commands Supported in ASCII personalities, Continued

FUNCTION	Command				
	Native Mode	Wyse WY-50+	ADDS VP A2	TVI 910+/925	PC Term
Read 80-column window/ page number and cursor address	ESC /	Same	ENH	Same	Same
Read cursor address in 80/132-column page	ESC b	Same	ENH		
Editing					
Clear all tab stops	ESC 0	Same	ENH	ESC 3	ESC 3
Set tab stop	ESC 1	Same	ENH	Same	Same
Clear tab stop	ESC 2	Same	ENH	Same	Same
Tabulate cursor	ESC i or CTRL I	Same	ENH	CTRL I	CTRL I
Backtab	ESC I	Same	ENH	Same	Same
Field tab				ESC I	ESC i
Insert mode on, replace mode off	ESC q	Same	ENH	ENH	ESC Z
Insert mode off, replace mode on	ESC r	Same	ENH	ENH	Same
Insert space character	ESC Q	Same	ENH	Same	Same
Insert line of spaces	ESC E	Same	ENH	Same	Same
Delete cursor character	ESC W	Same	ENH	Same	Same
Delete cursor line	ESC R	Same	ESC I	Same	Same
Clearing Data					
Clear page to nulls	ESC *	Same	ENH	Same	Same
Clear page to spaces	ESC +	Same	ENH		
Clear page to write-protected spaces	ESC ,	Same	ENH		Same
Clear unprotected page to spaces	ESC ; or CTRL Z	Same	ESC ; ENH	ESC ; or ESC +	Same
Clear unprotected page to nulls	ESC :	Same	ENH	Same	Same
Clear unprotected page to a specific character	ESC .char	Same	ENH		
Clear unprotected page to protected spaces				ESC ,	
Clear unprotected page to display attribute		ESC ! attr	ENH	ENH	
Clear unprotected page to spaces from cursor	ESC Y	Same	ESC k	Same	Same
Clear unprotected page to nulls from cursor	ESC y	Same	ENH	Same	Same
Clear unprotected line to spaces from cursor	ESC T	Same	ESC K	Same	Same
Clear unprotected line to nulls from cursor	ESC t	Same	ENH	Same	Same
Fill page with H's					ESC F
Sending data					
Begin print / send at top of page	ESC d'	Same	ENH		
Begin print / send at top of screen	ESC d&	Same	ENH		
Send cursor character	ESC M	Same			
Send line through cursor	ESC 6	Same	Same	ESC 6	
Send unprotected line through cursor	ESC 4	Same	Same	ESC 4	
Send page through cursor	ESC 7	Same	ENH	Same	ESC 7
Send unprotected page through cursor	ESC 5	Same	Same	ESC 5	

Commands Supported in ASCII personalities, Continued

FUNCTION	Command				
	Native Mode	Wyse WY-50+	ADDS VP A2	TVI 910+/925	PC Term
Mark block beginning	ESC 8	Same	ENH		
Mark block end	ESC 9	Same	ENH		
Send entire block	ESC s	Same	ENH	Same	Same
Send unprotected	ESC S	Same	ENH	Same	Same
Report terminal status					ESC [
Report attribute under cursor					ESC D
SPrint Functions					
Print formatted page	ESC P	Same	ENH	Same	Same
Print formatted unprotected page	ESC @	Same	ENH		
Print unformatted page	ESC p or ESC L	Same	ESC p	ESC L*11	
Select Parallel printer	ESC d (Same	Same		
Select Serial printer	ESC d)	Same	Same		
Auxiliary print mode off	CTRL T	Same	Same	ESC A	ESC A
Auxiliary print mode on	CTRL R	Same	Same	ESC @	
Transparent print mode off	CTRL T	Same	ESC 4	ESC a	ESC a
Transparent print mode on	ESC d #	Same	ESC 3	ESC `	ESC `
Bidirectional mode off	ESC d \$			CTRL T	CTRL T
Bidirectional mode on	ESC d %			CTRL R	CTRL R
Auxiliary receive mode off	ESC d SPACE				
Auxiliary receive mode on	ESC d !				
Set print terminator				ESC p	ESC p
Define delimiters				ESC x	ESC x
Character Sets					
Select primary character set	ESC c D	Same			
Select secondary character set	ESC c E	Same			
Define primary character set	ESC c B bank	Same			
Define secondary character set	ESC c C bank	Same			
Load font bank with predefined	ESC c @ bank	Same			
	set				
Clear font bank	ESC c ? bank	Same			
Define and load character	ESC c A bank	Same			
	pp bb...bb				
	CTRL Y				

*1. PCG ALPHA in Mono. Text Model machine.

*3. Valid only in Color Model machine.

*4. With enhance mode off.

*5. With enhance mode on.

*6. Automatically display in native mode. May be hidden by assigning blank attribute (ESC A | I).

*7. Screen cleared.

*8. If screen is not split.

*9. In WY-325 only

*10. In TeleVideo 925 only

*11. In TeleVideo 910+ only

answer up to characters to define answerback message

attr	Display Attributes	attr	Display Attributes
SPACE	Space character	p	Dim
0	Normal	q	Dim and invisible
1	Blank	r	Dim and blink
2	Blink	s	Dim, blink, invisible
3	Blink and Blank	t	Dim and reverse
4	Reverse	u	Dim, reverse, invisible
5	Reverse and invisible	v	Dim, reverse, blink
6	Reverse and blink	w	Dim, reverse, blink invisible
7	Reverse, blink, invisible	x	Dim and underline
8	Underline	y	Dim, underline, invisible
9	Underline and invisible	z	Dim, underline, blink
:	Underline and blink	{	Dim, underline, blink invisible
;	Underline, blink, invisible		Dim, underline, reverse
<	Underline and reverse	}	Dim, underline, reverse invisible
=	Underline, reverse, invisible	~	Dim, underline, reverse blink
>	Underline, reverse, blink	DEL	Dim, underline, reverse blink, invisible
?	Underline, reverse, blink invisible		

bank	Font Bank*a	bank	Font Bank*a
0	Font bank 0	2	Font bank 2
1	Font bank 1	3	Font bank 3

*a Holds predefined character set

baud	Baud Rate	baud	Baud Rate	baud	Baud Rate	baud	Baud Rate
0	115200	4	19200	8	2400	<	200
1	76800	5	9600	9	1200	=	134.5
2	57600	6	7200	:	600	>	110
3	38400	7	4800	;	300	?	50

bb...bb 32-byte character string defining bit pattern of character

bcolor	Background Color	bcolor	Background Color
1	Black	5	Red
2	Blue	6	Magenta
3	Green	7	Yellow
4	Cyan	8	White

ccc One-to three-decimal value of column relative to home
char Character that replaces unprotected characters
col See line/col

color	Color	color	Color	color	Color
1	Black	6	Magenta	D	Dim cyan
2	Blue	7	Yellow	E	Dim red
3	Green	8	White	F	Dim magenta
4	Cyan	B	Dim blue	G	Dim yellow
5	Red	C	Dim green	H	Dim white

cursor	Cursor Display	cursor	Cursor Display
0	Cursor display off	3	Blinking line cursor
1	Cursor display on	4	Steady line cursor
2	Steady block cursor	5	Blinking block cursor

cursor1	Cursor Display	cursor1	Cursor Display
0	Cursor display off	3	Blinking line cursor
1	Blinking block cursor	4	Steady line cursor
2	Steady block cursor		

dir	Direction
0	Normal
1	Remote
2	Local

fcolor	Foreground Color	fcolor	Foreground Color
1	Black	5	Red
2	Blue	6	Magenta
3	Green	7	Yellow
4	Cyan	8	White

Key	field Unshifted	field shifted	Key	field Unshifted	field shifted
F1	0	P	F7	6	V
F2	1	Q	F8	7	W
F3	2	R	F9	8	X
F4	3	S	F10	9	Y
F5	4	T	F11	:	Z
F6	5	U	F12	;	[

Function key	fkey Unshifted	fkey Shifted	Function key	fkey Unshifted	fkey Shifted
F1	@	`	F7	F	f
F2	A	a	F8	G	g
F3	B	b	F9	H	h
F4	C	c	F10	I	i
F5	D	d	F11	J	j
F6	E	e	F12	K	k

hndshk	Handshaking Protocol Receive	Transmit
0	None (default)	None (default)
1	XON/XOFF	XON/XOFF
2	DTR	
3	Both	

Keyboard Style

key	Enhanced PC	key	Enhanced PC	key	Enhanced PC
SPACE	ESC	&	SHIFT TAB →	\$	RETURN
%	SHIFT ESC	"	← BACKSPACE)	SHIFT RETURN
!	TAB →	'	SHIFT ← BACKSPACE	*	HOME
/	SHIFT HOME	3	SHIFT →	6	SHIFT DELETE
+	↑	s	ENTER kpd	R	PRINT SCREEN
0	SHIFT ↑	4	SHIFT ENTER kpd	X	SHIFT PRINT SCREEN
,	↓	q	INSERT	\	END
1	SHIFT ↓	p	SHIFT INSERT]	SHIFT END
-	←	r	PAGE DOWN	:	PAGE UP
2	SHIFT ←	w	SIFT PAGE DOWN	;	SHIFT PAGE UP
.	→	5	DELETE		

label 9 characters (80 columns); 7 characters (132 columns)

lattr Line Attribute

@	Single-high, single-wide characters
A	Single-high, double-wide characters.
B	Top half of double-high, single-wide characters
C	Bottom half of double-high, single-wide characters
D	Top half of double-high, double-wide characters
E	Bottom half of double-high, double-wide characters

ldraw	Graphics Character	ldraw	Graphics Character
0	┌	8	┐
1	└	9	┑
2	┌	:	─
3	└	;	■
4	┌	<	□
5	└	=	┘
6	┌	>	□
7	■	?	■

length	Multiple	Length of Page
G	1xlines	Equal to the number of data lines
H	2xlines	Double the number of data lines
I*b	4xlines	Four times the number of data lines

*b Available only in WY-50+ personality.

Line/Column	line/col*c	Line/Column	line/col*c	Line/Column	line/col*c	Line/Column	line/col*c
1	space	25	8	49	P	73	h
2	!	26	9	50	Q	74	i
3	"	27	:	51	R	75	j
4	#	28	;	52	S	76	k
5	\$	29	<	53	T	77	l
6	%	30	=	54	U	78	m
7	&	31	>	55	V	79	n
8	'	32	?	56	W	80	o
9	(33	@	57	X	81	p
10)	34	A	58	Y	82	q
11	*	35	B	59	Z	83	r
12	+	36	C	60	[84	s
13	,	37	D	61	\	85	t
14	-	38	E	62]	86	u
15	.	39	F	63	^	87	v
16	/	40	G	64	_	88	w
17	0	41	H	65	`	89	x
18	1	42	I	66	a	90	y
19	2	43	J	67	b	91	z
20	3	44	K	68	c	92	{
21	4	45	L	69	d	93	
22	5	46	M	70	e	94	}
23	6	47	N	71	f	95	~
24	7	48	O	72	g	96	DEL/RUB

*c Native codes also recognized in WY-50+, TVI 910+/925, and PC Term personalities, and in ADDS VP A2 personality absolute cursor addressing.

/// One- to three-decimal value of line relative to home

map	Definition	map	Definition
1	Normal	5	Underline
2	Reverse (or blank*d)	6	Underline and reverse (or blank*d)
3	Intensity	7	Underline and intensity
4	Intensity and reverse (or blank*d)	8	Underline, intensity, and reverse (or blank*d)

*d. Colors mapped to reverse or blank depending on the setting of the Color Map setup parameter or the equivalent escape sequences.

max	Maximum Speed
1	60 characters per second
2	No limit (default)
3	150 characters per second

message 46 characters (80 columns); 98 characters (132 columns)

mf	Screen Area*e	mf	Screen Area*e
0	Data area	2	Terminal message field
1	Function key label line	3	Computer message field

*e In native mode, only the reverse attribute can be assigned to the data area.

p1	Function Key	p1	Function Key
1	F1	6	F6
2	F2	7	F7
3	F3	8	F8
4	F4	9	F9
5	F5	0	F10

p2	Direction
1	Remote
2	Local
3	Normal

<u>length</u>	<u>Multiple</u>	<u>Length of Page</u>
<i>page</i>	<i>Page</i>	
0	page 0	In the 80 columns mode: There have 4 pages of display memory.
1	page 1	In the 132 columns mode: There have 3 pages of display memory.
2	page 2	In the Econ-80 columns mode: There have 7 pages of display memory.
3	page 3	
4	page 4	
5	page 5	
6	page 6	

<u>palette</u>	<u>Color Palette</u>	<u>palette</u>	<u>Color palette</u>	<u>palette</u>	<u>Color palette</u>
0	Palette 0	4	Palette 4	8	Palette 8
1	Palette 1	5	Palette 5	9	Palette 9
2	Palette 2	6	Palette 6	.	Palette 10
3	Palette 3	7	Palette 7		

<u>parity</u>	<u>Parity Bits</u>	<u>parity</u>	<u>Parity Bits</u>
0	None	2	Mark
1	Odd	3	Even

pp 2-byte hex value of character position**f*.
**f* In the illustrations, DEC = decimal value; HEX = hexadecimal value. Read across, then down.

<u>scroll</u>	<u>Scrolling Type</u>	<u>Speed(lps)</u>
@	Jump scroll	
<	Smooth scroll	1
=	Smooth scroll	2
>	Smooth scroll	4
?	Smooth scroll	8

sequence Up to 64 bytes to be loaded in function key

<u>set</u>	<u>Predefined Character Set</u>
@	Native Mode
A	PC Multinational
B	Standard ASCII
D	PC Standard
G	Standard ANSI

<u>stop</u>	<u>stop bits</u>
0	1
1	2

text 78 characters (80 columns); 130 characters (132 columns)

<u>volume</u>	<u>BELL Volume</u>	<u>volume</u>	<u>BELL Volume</u>
#	Loud	!	Low
"	Medium	SP	Off

<u>wnd/</u>	<u>Window or Page</u>
0	Page 0 or upper window
1	Page 1 or lower window

<u>word</u>	<u>Data Word</u>
0	7 bits
1	8 bits

<u>wpc</u>	<u>Write-Protected Display Attribute</u>	<u>wpc</u>	<u>Write-Protected Display Attribute</u>
6	Reverse* <i>g</i>	C	Invisible on
7	Dim* <i>g</i>	E	Underline on
A	Normal* <i>g</i>	F	Reverse on
B	Blink on	G	Dim on
* <i>g</i>	Clears other write-protected attributes		

wpcal	Display Attribute	wpcal	Write-Protected Display Attribute
@	<i>Normal</i>	H	<i>Normal</i>
A	<i>Dim</i>	I	<i>Dim</i>
B	<i>Blink</i>	J	<i>Blink</i>
C	<i>Dim/Blink</i>	K	<i>Dim/Blink</i>
D	<i>Invisible</i>	L	<i>Invisible</i>
P	<i>Reverse(Rev)</i>	X	<i>Reverse(Rev)</i>
Q	<i>Rev/Dim</i>	Y	<i>Rev/Dim</i>
R	<i>Rev/Blink</i>	Z	<i>Rev/Blink</i>
S	<i>Rev/Dim/Blink</i>	[<i>Rev/Dim/Blink</i>
T	<i>Rev/Invisible</i>	\	<i>Rev/Invisible</i>
.	<i>Underline(UL)</i>	h	<i>Underline(UL)</i>
a	<i>UL/Dim</i>	i	<i>UL/Dim</i>
b	<i>UL/Blink</i>	j	<i>UL/Blink</i>
c	<i>UL/Dim/Blink</i>	k	<i>UL/Dim/Blink</i>
p	<i>UL/Rev</i>	x	<i>UL/Rev</i>
q	<i>UL/Rev/Dim</i>	y	<i>UL/Rev/Dim</i>
r	<i>UL/Rev/Blink</i>	z	<i>UL/Rev/Blink</i>
s	<i>UL/Rev/Dim/Blink</i>	{	<i>UL/Rev/Dim/Blink</i>

1. Introduction

There are two ways to send the print jobs to Ethernet Terminal for printing: 1) through LPD protocol, and 2) through TFTP protocol. The first method is more suitable for printing environments with a large number of user. The reason for this is since the LPD protocols has a queue process so that the print jobs will be kept in the print queues in the host. But TFTP does not implement the print queue concept; if printer port is not ready for accepting new print jobs, TFTP will be terminated. Consequently, the user must send the print job again. Thus the TFTP protocol is suitable for printing small jobs, in a small number of users environment, or for testing purposes.

LPD is a built-in printing protocol in the BSD type of UNIX. However, it is also available in most UNIX system. With LPD, users do not need to install additional software to the host to print the jobs. Most implementations of the LPD protocol sends out the data file before the control file. However, since Ethernet Terminal must print the data file immediately upon receiving it, then the print option specified in the control file cannot take affect.

To install the printer server function of Ethernet Terminal, the first step is Basic setup. Whichever printing protocol you use, you need to run basic setup first. If you plan to use LPD to print your jobs, you need to go through the Setup for LPD procedures. If you plan to use TFTP to print your jobs, you need to go through the Setup for TFTP procedures.

2. Basic Setup

Because the TCP/IP world uses IP addressing to communicate with each other, the purpose of Basic Setup is to assign an IP address to the Ethernet Terminal.

For the purpose of these explanation, assume the following:

- (1) Login to the UNIX host as root
- (2) Your Ethernet terminal is on the same network segment that the host resides.

Step 1. Add the Print Server to /etc/hosts

Create a new entry in the /etc/hosts file on all UNIX hosts that are slated to work with Ethernet Terminal.

To create a new entry, add the following line:

IP_Address PS_NAME # comment

where: IP_Address is an IP address.
PS_NAME is a host name of a print server.
The statement after # is the comment for the new entry.

e.g. 192.168.0.2 ETPS1 # Ethernet Terminal

This example assigns the name ETPS1 to the Ethernet Terminal with IP address 192.168.0.2.

NOTE: The IP address is defined in setup Screen of Cosole Terminal as a local IP address. You can change it by yourself.

Step 2. Check to see if above steps are completed

You can check if the IP address of print Server function is installed successfully by issuing the following ping command:

ping PS_NAME [Enter]

e.g. ping ETPS1 [Enter]

3. Setup for LPD

Follow those steps from step 1 to step 2 described in Basic Setup. The following steps are dependent on the operating system. Please refer to the UNIX administration guide. The following illustrated steps are under BSD system.

Step 3. Create a spooling directory
Use mkdir command to create a directory for spooling.
e.g. mkdir/usr/spool/ETPS1

Step 4. Make the directory be available to LPD main process
Basically, the method has the following three procedures:
1) Assign the spooling daemon as the owner of this directory.
2) Allow the spooling daemon to be able to read from or write to the directory.
3) Enable the group of LPD main processes to be able to read from or write to the directory.

e.g. If it works on a BSD UNIX host and makes the directory **/usr/ spool/ETPS1** (created in step 3) available, then follow these three procedures:

```
chown daemon /usr/spool/ETPS1
chmod 775 /usr/spool/ETPS1
chgrp daemon /usr/spool/ETPS1
```

Step 5. Add a remote printer
To add a remote printer, insert a block similar to the following in the /etc/printcap file.

```
Printer_name|Remote Printer on Ethernet Terminal:\
:lp=\
:rm=PS_NAME:\
:rp=Logic_Printer_name:\
:sd=<full path of spooler directory name>:\
:mx#0:
```

e.g. If Ethernet Terminal works on a BSD UNIX host, then insert the following block into /etc/printcap file.

```
ETPS1|Remote Printer on Ethernet Terminal:\
:lp=\
:rm=ETPS1:\
:rp=L1:\
:sd=/usr/spool/ETPS1:\
:mx#0:
```

Step 6. Start host's print mechanism for BSD version UNIX system
Typing: lpc start printer_name [Enter]
e.g. lpc start ETPS1 [Enter]

Now your Ethernet Terminal is configured to accept LPD printing..

4. LDP Printing

Before you use LPD for printing, your Ethernet Terminal needs to be installed completely with Setup for LPD in 3 setup for LPD. LPD protocol is built-in to most of the UNIX system. However, detailed implementation of LPD differs among UNIX system. Please refer to your UNIX administration guide for reference. The following illustrated printing command is under BSD system or System V version.

For BSD system: `lpr -P <printer_name><filename>`

For System V version: `lp -d <printer_name><filename>`

This command is to print selected file to the selected printer.

e.g. `lpr -PETPS1 /etc/hosts` (BSD version) or `lp -dETPS1 /etc/hosts` (System V version)
This example is to print the `/etc/hosts` file to the Ethernet Terminal printer.

5. Setup for TFTP

If you are working on the BSD UNIX system, please run the setup procedure as 3 setup for LPD. Otherwise run the setup procedure as LPD except step 6.

6. TFTP Printing

Before you use TFTP printing, your Ethernet Terminal needs to be installed completely by Basic Setup for TFTP in 5. TFTP Printing lets you send print jobs to the printers directory. There are no spooling mechanisms involved. Consequently, in case that printer is not ready, the TFTP process will be terminated immediately without sending print jobs to printers. The user need to make sure the printer is ready to print then issue TFTP command to have a successful result.

Firstly, you should log into the Ethernet Terminal with this command:

```
tftp <PS_NAME>
```

And then type:

```
put <file Name> Ln
```

Where Ln is a logic printer for L1 to L8

e.g. `tftp ETPS1`
`tftp > put /etc/hosts L1`

This example prints the `/etc/hosts` file to the logic printer 1 of Ethernet Terminal Printer ETPS1.

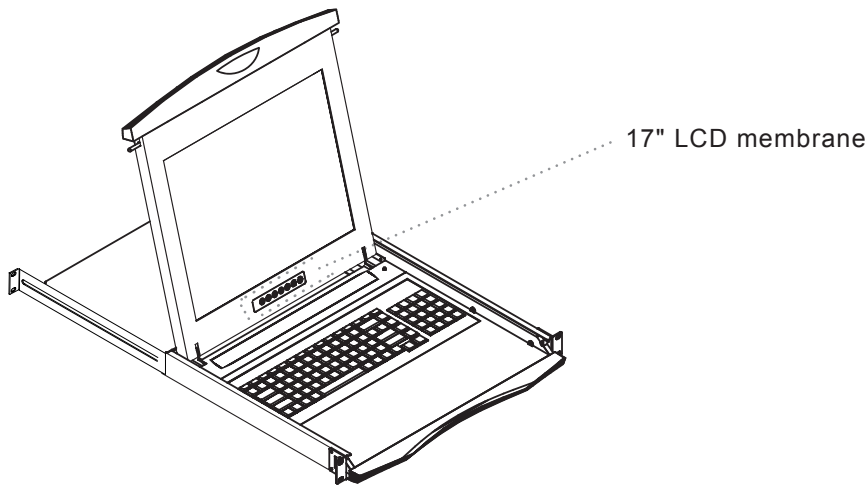

Membrane Switch	Function
<ul style="list-style-type: none"> ○ ● ● 	Power light Green = On Orange = Power saving
⊖	Power on / off LCD
M	Display the OSD menu
	Scrolls through menu options and adjusts the displayed control
	Exit the OSD screen Shortcut key to auto adjustment by pressing the button for 5 seconds

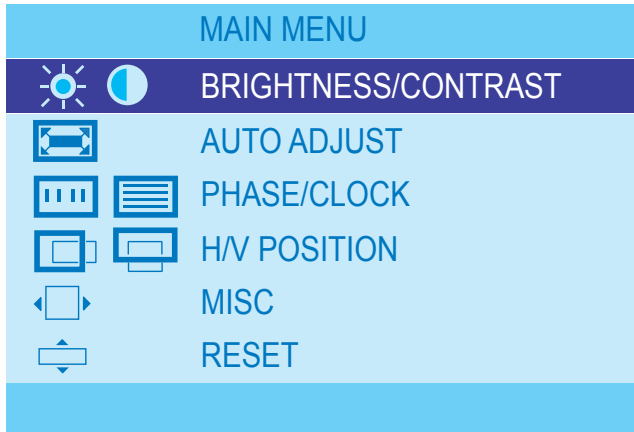

BRIGHTNESS / CONTRAST

Brightness: Adjust background black level of the screen image.

Contrast: Adjust the difference between the image background (black level) and the foreground (white level).

AUTO ADJUST

Auto Adjust: Fine tunes the video signal to eliminate waviness and distortion. An "Adjusting" message is displayed during the process.

Auto Tune: Optimize phase, clock, position and size. An "Adjusting" message is displayed during the process.

PHASE/CLOCK

Phase / Clock: To enter into the phase & clock sub menu.

H/V POSITION

H/V Position: Align the screen image left or right and up or down.

MISC

Information: Display the current resolution, refresh rate and frequency information on the screen.

OSD Timer: Set the time duration in seconds that the OSD is visible after the last button is pressed. The factory default is 10 seconds.

Color: Select the screen color - 5500K, 6500K & 9500K. The factory default is 9500K.

Language: Select the language in which the OSD menu is displayed - English, Chinese (中文), Japanese (日本語), German, French, Spanish, Italian.

RESET

Restore the settings to factory defaults.

Item		Description
Form Factor		1U rack mounting on slide-out rails
LCD Manufacturer		
Diagonal Size		17" TFT
Max. Resolution		800 x 600
Brightness (cd/m ²)		300
Contrast Ratio (typ.)		1000:1
Viewing Angle (H/V)		160° x 160°
Display Area (mm)		338 x 270
Color Support		16 colors
LCD Panel MTBF (hrs)		50,000
Communications	Serial Port	One DB9 male RS-232C port
	Network Port	One RJ45 10Base-T Ethernet port
	Local Print Port(s)	One DB25 female parallel & 1 x DB9 male RS-232
	Serial Baud Rate	50 to 115,200 bps
	Serial Data Format	7 or 8 data bit with or without parity, 1 or 2 stop bits
	Serial Handshake	Xon / Xoff, XPC and hardware DTR
	Access option	1 x RS-232 serial connection, or Up to 12 Ethernet telnet sessions to pre-set IP address. Serial and Ethernet connections cannot be used concurrently
Terminal Emulation	Emulations	VT52, V100, VT200, Console ANSI, PC Term, TVI910+ / 925, WY-50+, WY-60, WY-100, WY-120, WY-325, PCG Alpha
	Screen Size	80 x 25
	Page Length	1, 2 or 4 screens
	Cursor	Blink or Steady, block or underline
	Modes	Full duplex, half duplex, block mode, half block mode
	Color Mode	16 foreground and 16 background colors
Power Input		Auto-sensing 100 to 240VAC, 50 / 60Hz
Power Consumption		Max. 40 Watt, Standby 5 Watt
Regulation Approval		FCC, CE

Options

IP Serial Console	Integrated with IP 16-port serial console
Keyboard	Multilingual keyboard selection
DC Power	DC power input with 12V, 24V, 48V selection

Environmental

Operation	0° to 50°C Degree
Storage	-5° to 60°C Degree
Relative Humidity	5~90%, non-condensing
Shock	10G acceleration (11ms duration)
Vibration	5~500Hz 1G RMS random vibration

Supporting layouts



N

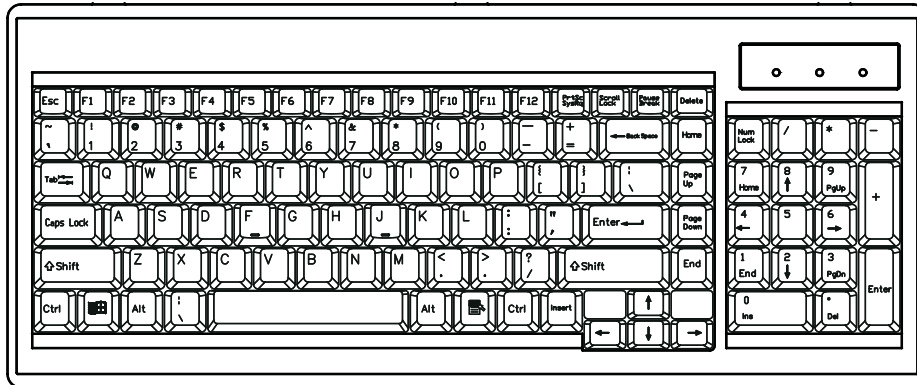

N keyboard with full numerical pad

- 104 keys (US / European / Chinese / Korean layout)
- 106 keys (Japan layout)
- PS/2 or USB connection

4.1 DC Power Options

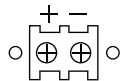

Chapter 4

Model	12V	24V	48V
Input rating			
Input voltage:	12-Volt	24-Volt	48-Volt
Input range:	9 ~ 18V	18 ~ 36V	36 ~ 75V
Input current			
- No load	50 mA	50 mA	50 mA
- Full load	4950 mA	2450 mA	1220 mA
Output rating			
Output voltage:	12-Volt	12-Volt	12-Volt
Output current:	4.16A	4.16A	4.16A
Efficiency	84%	85%	85%

Remarks :

- Package does not include power cord and AC power adapter

1. The membrane button power light is not ON

Press the power On / Off on LCD membrane button to check if the monitor is in the ON mode.
Check the power cord is properly connected to the LCD keyboard drawer and power outlet.

2. Screen image is not centered or sized properly

Press the  button for two seconds to automatically adjust the image.
Adjust the H-position and V-position settings via On-screen menu.

3. The screen of NCP-1701 does not fit the monitor after auto adjust

You need to change the display setting as below :

- (1) Hold down the Alt and then depress the Esc key to enter setup mode.
- (2) Press F1 for display setup menu, select the Display by arrow key.
- (3) Press Spacebar to change Display = LCD
- (4) Then press F12 to exit, and press Spacebar save the setting.

Remark : Scroll lock must be off for accessing setup menu by "Alt + Esc" key

4. What devices and servers can the NCP-1701 console terminal LCD keyboard drawer be used with ?

The NCP-1701 console terminal LCD keyboard drawer is based on the RS-232-C protocol standard supported on most terminals, PCs, servers, as well as many manageable devices which equipped with at least one RS-232 serial port that is used as a console port when no keyboard is present.

5. Can I connect the NCP-1701 to single SUN server using an Ethernet telnet connection ?

Yes, you can establish an Ethernet telnet connection by applying a crossover Ethernet cable in between Ethernet RSC console port of SUN server and Ethernet port of NCP-1701. Alternatively, an Ethernet switch and standard RJ45 cat 5 Ethernet cables may be used. When using an Ethernet switch, it is advisable that this network remains private for security reason.

6. How do I connect the NCP-1701 to multiple servers using a RS232 serial connection?

A multi-port IP serial console (CS-116 / CS-148) or multi-port console server must be used to connect the console terminal to multiple servers.

7. How do I connect the NCP-1701 to multiple servers using an Ethernet telnet connection?

An Ethernet switch must be used to connect the NCP-1701 to multiple servers. Standard RJ45 Cat5 Ethernet cables should be used to connect the switch to the NCP-1701 and servers.

In use, the operator can switch the terminal connection between [up to] 12 servers by using the hot key sequence ALT-F1 through to ALT-F12. The state of each server session is preserved by the console NCP-1701.

8. How many servers are supported by the Ethernet telnet connection?

The console terminal allows up to 12 Ethernet connected servers to be configured.

9. Does the console terminal require an IP address when using an Ethernet connection?

Yes. The IP address is pre-defined during console terminal set up.

10. Is any configuration required for SUN server ?

When the NCP-1701 loses power or is powered off, a 'break' may be generated on the RS-232 host communications port (as is common with most general purpose terminals). To prevent this halting a Sun server, ensure that the "alternate break" sequence is configured.

When connecting the NCP-1701 to IP serial console (CS-116 / CS-148) or console server, an alternate break sequence may not be required, since some IP serial consoles or console servers are "Break Safe". When using an Ethernet console connection, the alternate break sequence need not be defined. However, the RSC Ethernet port must be configured using the "rsconfig" command.

11. Does the keyboard support any Sun specific keys?

No, character terminals are non Sun specific, and do not require any special keys.

12. What character resolutions does the console terminal support?

The standard resolution is 80x24 plus a status line displayed using 800x600 pixels.

Model	Product Dimension (W x D x H)	Packing Dimension (W x D x H)	Net Weight	Gross Weight
NCP-1701	442 x 650 x 44 mm 17.4 x 25.6 x 1.73"	589 x 856 x 168 mm 23.2 x 33.7 x 6.6"	16 kg 35 lb	22 kg 48 lb

The company reserves the right to modify product specifications without prior notice and assumes no responsibility for any error which may appear in this publication.

All brand names, logo and registered trademarks are properties of their respective owners.

Copyright 2008 Austin Hughes Electronics Ltd. All rights reserved.